

Conectiv Power Delivery

Technical Considerations Covering Parallel Operations of Customer Owned Generation Of One (1) Megawatt or Greater And Interconnected with the Conectiv Power Delivery System

March 30, 2004

Table of Contents

<u>Topics</u>	<u>Page No.</u>
Disclaimer	3
Perquisites	3
Applicability	3
Definitions	4
Introduction and Purpose	7
Generator Owner Obligations	8
Conectiv Power Delivery Obligations	10
Technical Design Considerations	11
Performance Considerations	21
Protection Scheme Details	25
Typical One-Line Diagrams	29
Interconnection Application	35
References	37
APPENDIX A (Generator Protection Guidelines 50 MW & Above)	39
APPENDIX B (Information To Be Supplied By Generator Owner)	42

I. Disclaimer

This document and all the material contained herein is designed for informational and illustrative purposes only. It is produced as an aid to those Customers contemplating the purchase of generation equipment and interconnecting this generation equipment with the Conectiv Power Delivery System. The information is intended only to guide the customer in making a decision on whether to proceed with a more detailed engineering study.

All the information in this document is intended to be typical and of a general nature for information purposes. It is not intended to be site or facility specific. Requirements and practices are also subject to change and it must be recognized that any given item may become obsolete in the future.

Conectiv Power Delivery, Atlantic City Electric Company and Delmarva Power & Light Company make no warranty of any nature whatsoever concerning the information contained in this document.

II. Prerequisites

To interconnect with the Conectiv Power Delivery System, the Customer must first be in compliance with the tariff rules and regulations and the applicable tariff classifications and rates. The terms and conditions contained within this document are in addition to, but do not modify nor negate, the terms of the tariff.

The Generator Owner must also negotiate an Interconnection Agreement Contract with the Company covering the use of Conectiv's facilities to enable the transfer of power from or to the Facility. The details of the Interconnection Agreement Contract are outside the scope of this document. However, this Technical Considerations Document may be included in and become part of the overall Interconnection Agreement Contract.

In addition to submitting an Interconnection Application to the Company, a Generator Owner may also be required to submit an Interconnection Request to PJM. PJM will initiate a process to study the feasibility of the generation, its impact within the PJM Grid and the cost to make any necessary Grid improvements. The extent of the studies is dependent on the size of the generation and the proposed Point of Common Coupling. Again, the details of this process are outside the scope of this document.

A Generator Owner must also complete an Interconnection Service Agreement with PJM if system upgrades are necessary.

III. Applicability

Unless otherwise provided, these technical considerations apply to all Customer owned generation operating at 1 MW or greater interconnected with and operating in parallel with the Conectiv Power Delivery System at voltages up to and including 500kV. Where multiple generators are connected to the Grid through a single Point of Common Coupling, the sum of the generator ratings will be used to determine the applicability of these Technical Considerations.

IV. Definitions

Various terms as utilized in this document are defined below. Whenever used in the document with initial capitalization, the following terms have the meanings specified in this Section.

- A. **Account** – An account is one metered or un-metered rate or service classification which normally has one electric delivery point of service. Each account shall have only one electric service supplier providing full electric supply requirements for that account. A premises may have more than one account.
- B. **Company** - Delmarva Power & Light Company, doing business as Conectiv Power Delivery or Atlantic City Electric Company, doing business as Conectiv Power Delivery.
- C. **Conectiv Power Delivery System** – The electric system of the appropriate affiliate of Conectiv, either Atlantic City Electric Company or Delmarva Power & Light Company, in whose geographic service area the Customer’s Facility is electrically connected. This should include all that affiliate’s electric facilities and systems located on that affiliate’s side of the Point of Common Coupling including that affiliate’s transmission and distribution systems.
- D. **Customer** - Any adult person, partnership, association, corporation, or other entity: (i) in whose name a service account is listed, (ii) who occupies or is the ratepayer for a premises, building, structure, etc., and (iii) who is primarily responsible for payment of bills. A Customer includes anyone taking Delivery Service or combined Electric Supply & Delivery Service from the Company under one service classification for one account, premises or site. Multiple premises or sites under the same name are considered multiple Customers.
- E. **Interface Transformer** - A transformer which interconnects a privately owned generation source with the Conectiv Power Delivery System voltage.
- F. **Facility (or Facilities)** – The Customer owned generating equipment and all associated or ancillary equipment, including Interconnection Equipment, on the Customer’s side of the Point of Common Coupling.
- G. **Generator Owner** – The owner of the Facility that is interconnected to the Company.
- H. **Grid** – The interconnected arrangement of lines, transformers and generators that make up the Company’s electric power system.
- I. **Interconnection** – The physical connection of Customer owned generation to the Conectiv Power Delivery System in accordance with these technical considerations so that parallel operation can occur.
- J. **Interconnection Application** – The standard form of application which must be submitted by the Generation Owner to the Company as a request to interconnect a generating unit to the Conectiv Power Delivery System or to increase the capacity of a generating unit already connected to the Conectiv Power Delivery System.
- K. **Interconnection Equipment** - That equipment necessary to interconnect the Facility to the Conectiv Power Delivery System, including any and all relaying, interrupting, metering or communication equipment needed to protect the Facility and the Conectiv Power Delivery System and to control and safely operate the Facility in parallel with the Conectiv Power Delivery System.
- L. **Inverter** – A static power converter with control, protection and filtering functions that converts Direct Current (DC) input to Alternating Current (AC) output. Inverters connected to the Conectiv Power Delivery System must be of the non-islanding type.

- M. **Island** – A portion of the Conectiv Power Delivery System containing both load and Customer owned generation that is electrically isolated from the remainder of the Conectiv Power Delivery System.
- N. **MAAC - Mid-Atlantic Area Council**. One of ten Regional Reliability Councils which form the North American Electric Reliability Council (NERC). MAAC is responsible for the mid-Atlantic region, including all or parts of the states of Pennsylvania, New Jersey, Delaware, Maryland, Virginia and the District of Columbia.
- O. **NERC - North American Electric Reliability Council**. The purpose of NERC is to ensure the adequacy, reliability and security of the bulk electric supply systems through coordinated operations and planning of generation and transmission facilities.
- P. **Parallel Operation** – Any electrical connection between the Conectiv Power Delivery System and the Generator Owner’s generation source.
- Q. **PJM - PJM Interconnection, L.L.C.** The Independent System Operator for the Pennsylvania, New Jersey Maryland area of the Northeast U.S. whose members include electric utilities and independently owned generating resources. The organization is responsible for dispatching generation, operating the bulk transmission system within its service area and operating a buy/sell market for member’s generation.
- R. **Point of Common Coupling (or PCC)** – The point where the electrical conductors of the Conectiv Power Delivery System are connected to the Generator Owner’s conductors and where any transfer of electric power between the Customer and the Company takes place.
- S. **Pre-Interconnection Study** – A technical study or studies which may be undertaken by either the Company and/or PJM in response to its receipt of a completed application for Parallel Operation with the Conectiv Power Delivery System submitted on the Interconnection Application form prescribed by these technical considerations or by PJM. Pre-Interconnection Studies may include, but are not limited to, service studies, coordination studies and facilities impact studies.
- T. **RTU - Remote Terminal Unit**. The remote unit of a supervisory control system used to telemeter operating data, provide device status/alarms and to provide remote control of equipment at a substation or generator site. The unit communicates with a master unit at the System Control Center.
- U. **Stabilized** – The state of the Company’s system following a disturbance which returns to the normal range of voltage and frequency for a least 5 minutes or longer as coordinated with the Company. The Company may require a longer time period upon a reasonable showing that reconnection after only 5 minutes will adversely impact the safety and reliability of the Conectiv Power Delivery System.
- V. **Stiffness Ratio** – A measure of how strong a generator’s fault current contribution is in comparison to the total fault current available at the Point of Common Coupling.

$$\text{Stiffness Ratio} = \text{Total fault current available at PCC} / \text{Generator Fault Contribution}$$
- W. **System Control Center** – The Company office that monitors and has direct control over the operation of the Conectiv Power Delivery System.
- X. **System Emergency** – An imminent or occurring condition on the Conectiv Power Delivery System, the PJM System, the system of a neighboring utility, or in the Facility, that is likely to

impair system reliability, quality of service, or result in significant disruption of service, or damage, to any of the foregoing, or is likely to endanger life, property or the environment.

V. Introduction and Purpose

Prior to the de-regulation of the electric power industry, the complete electric Grid including generation was owned and operated by the electric utility. The electric utility had full knowledge and complete control of all generation equipment connected to the Grid. Therefore, any new utility generation was designed by the utility to integrate into the overall electric system.

The restructuring of the electric power industry, the development of an open market for electric power generation and the advent of technical advances in generator technologies have resulted in privately owned generators being connected to the utility electric Grid. The intent of this document is to outline the basic requirements to those Customers who are contemplating the installation of privately owned generation connected to, and operated in parallel with, the Conectiv Power Delivery System. The information contained in this document is to provide the proposed Generation Owner with Company and Generator Owner obligations, technical and safety requirements and the need for adequate protective equipment to be designed and installed by the Generator Owner, in order to operate one or more generator units in Parallel Operation with the Conectiv Power Delivery System, without adversely impacting the reliability of electric service to other Customers, or the safety of the general public and Company employees. As such, the emphasis of this document deals with the protection of the generator equipment and the utility system. The information should be useful in understanding the need for a proper design and the analysis needed to complete a comprehensive interconnection feasibility study.

Some aspects of interconnected parallel generation are not fully addressed in this document. Metering and remote monitor/control requirements are covered only at a high level, with detailed requirements beyond the intended scope of this document. Detailed metering and remote monitor/control requirements will have to be reviewed on a case-by-case basis.

No one document can provide all the details needed to cover every conceivable generator installation. Consequently, this document is provided only as a starting point and a source of preliminary information. Any Customer considering the installation of interconnected generation will have to consult all available resources, design standards and professionals necessary to develop a feasible design and installation.

VI. Generator Owner Obligations

In the course of owning, interconnecting and operating a generator in parallel with the Conectiv Power Delivery System, the Generator Owner is responsible for the following obligations:

- A. The Generator Owner must design and construct his Facility to meet all applicable national, state and local construction and safety codes.
- B. The Generator Owner must design his Facility with protective hardware and software to prevent the generator from energizing any Company de-energized circuit.
- C. The Generator Owner must design his Facility with protective hardware and software to automatically disconnect from the Company Grid if the source from the Conectiv Power Delivery System is lost, irrespective of connected loads or other generators on the circuit. Islanding of customer owned generation with other Customers will be permitted only if specific contractual arrangements have been made and necessary equipment has been installed by the Generator Owner to control and stabilize voltage and frequency within the island.
- D. The Generator Owner must equip his Facility with the necessary protective hardware and software designed to prevent sustained Parallel Operation of the generator with the Conectiv Power Delivery System unless the system service voltage and frequency are within acceptable magnitudes as defined in Sections IX - B and C.
- E. The Generator Owner is responsible for protecting his own Facility in such a matter that Company Grid outages, short circuits, single phasing conditions or other disturbances including zero sequence currents and ferroresonant overvoltages do not damage the Generator Owner's equipment.
- F. The Generator Owner is responsible for protecting his generator and equipment from the effects of switching or automatic reclosing on the Conectiv Power Delivery System circuit(s) supplying the Generator Owner's Facility.
- G. The Generator Owner shall insure that his designs utilize equipment properly sized to meet the operating voltage, current rating, fault duty etc. necessary for the site.
- H. The Generator Owner is responsible for protecting its own generator and all interconnection / ancillary equipment. The Generator Owner must supply the required protection schemes along with the necessary metering and monitor/control requirements specified either by Conectiv Power Delivery or by PJM.
- I. The design, procurement, installation and maintenance of all equipment at the Generator Owner's Facility are the responsibility of the Generator Owner. The Generator Owner is responsible for all costs.
- J. The Generator Owner will supply the Company with the necessary technical information, one-lines, equipment data, specifications, etc. so that so that the Company can conduct a complete review of the proposed Facility and conduct any necessary studies. (See Appendix B)
- K. The Generator Owner will cover the expense of any Company service study, coordination study or facility impact study necessary to assess the impact of the interconnected generation. The scope of such Pre-Interconnection Studies will be based on the generator characteristics and the proposed Point of Common Coupling. (The expense shall be directly reimbursed to the Company or through PJM.)

- L. Any necessary enhancements or improvements needed within the Conectiv Power Delivery System and/or at other Customer sites to accommodate the Parallel Operation of the Generator Owner's generator will be at the Generation Owner's cost, unless otherwise allocated in accordance with PJM Transmission Tariff or PJM Operating Agreement.
- M. The Generator Owner has full responsibility and liability for the safe and proper operation and control of their equipment and for the power originating from their generator.
- N. The Generator Owner is responsible for synchronizing their generator to the Conectiv Power Delivery System and maintaining a synchronous condition.
- O. The Generator Owner shall maintain their Facility in good working order, consistent with industry standards, manufacturer recommendations, and in compliance with all applicable rules, codes and regulations. The Generation Owner shall have a maintenance and testing program that ensures all protective schemes and equipment are periodically calibrated and functionally tested. *PJM Relay Testing and Maintenance Practices* shall be followed for all facilities participating in the PJM marketplace, or interconnected at 230kV and above.
- P. The Generator Owner must immediately cease parallel operation upon notification by the Company that their operation is unsafe, interferes with the quality of supply to other Customers or interferes with the Company's system maintenance or operation.
- Q. The Generator Owner will connect and disconnect their generator to/from the Conectiv Power Delivery System only under the direction and approval of the Company's System Control Center.
- R. The Generator Owner will obtain and cover the cost of any required communication circuits to their site for protective relaying, generator monitoring/control, metering, and equipment remote access.
- S. The generator must not be connected in parallel with the Conectiv Power Delivery System until the Company has granted approval to interconnect and the Generator Owner has received notification.
- T. The Generator Owner will apply a Warning Label provided by the Company in a conspicuous place on or near their meter, meter box, breaker or Point of Common Coupling to notify Company personnel that there is a generator source at the site.
- U. The Generator Owner must notify the Company in writing if it intends to add or modify any equipment at its Facility that impacts the protection associated with the Point of Common Coupling. The Generator Owner must also give the Company reasonable advance notice if it intends to permanently shut down their generation.
- V. The Generator Owner shall maintain an operating log at their Facility which details all changes in operating status, trip occurrences, maintenance outages or other unusual conditions found upon inspection. The Company may require other information to be logged. The Generator Owner and the Company will generally negotiate the specific information that must be logged at each site. The operating log shall be available to the Company upon request and shall be maintained by the Generator Owner at their Facility.
- W. The Generator Owner must accept the fact all Customers including Generator Owners may be switched temporarily or permanently from one Conectiv Power Delivery circuit to another in response to such causes as load growth, equipment failure, maintenance outages etc. The Generator Owner is responsible for any redesign or setting adjustments in their Facility that are necessary to accommodate their transfer to another Company circuit.

VII. Conectiv Power Delivery Obligations

In negotiation, in reviewing an Interconnection Application and in ongoing operation with a Generator Owner, the Company is responsible for the following obligations:

- A. The Company will provide the Generator Owner with the Conectiv Power Delivery System available fault current, system impedance and protection system details at the proposed Point of Common Coupling. This data will be updated, as required, when significant system changes occur.
- B. The Company will review the proposed Facility and make all necessary Pre-Interconnection Studies to evaluate the impact of the generator on the Conectiv Power Delivery System and identify any system enhancements necessary. The Company should complete this review in a timely manner.
- C. The Company will review and provide feedback to the Generator Owner on the proposed design and protection schemes associated with the Point of Common Coupling. The Company may also review and provide comment on the generator protection and protective relay settings. However, any review by the Company does not relieve the Generation Owner of full responsibility for the protection of their generator and equipment.
- D. The Company will provide the Generation Owner with the technical details and requirements necessary to satisfy the generator metering and RTU monitoring/control needs for each specific generator installation site.
- E. The Company will provide written approval or enter into an appropriate agreement for the interconnection of the Generator Owner's Facility as soon as all requirements are satisfied. Such approval does not, however, supercede the Generator Owner's obligations or imply that the Facility meets all federal, state and local standards. If not approved, the Company will provide details on the reason or reasons for denying the parallel interconnection.
- F. The Company, in the course of reviewing applications for interconnected parallel generators and making any necessary Pre-Interconnection Studies, has the need for detailed information on the proposed Generator Owner's Facility. The Company or any of its affiliates shall not use such knowledge and information submitted by the proposed Generator Owner to offer competing services or special rate considerations. In addition, the Company will not divulge this information to a third party.
- G. The Company may disconnect and isolate the Generator Owner's Facility from the Conectiv Power Delivery System for routine maintenance and repairs on the Company's Grid consistent with applicable tariffs and agreements. The Company will make reasonable efforts to provide advance notice to the Generator Owner of service interruptions resulting from routine maintenance. The Company will reconnect the Generator Owner's Facility as quickly as possible following any such service interruption.
- H. The Company reserves the right to disconnect and isolate the Generator Owner's Facility from the Conectiv Power Delivery System for System Emergencies or unsafe conditions without notice. The Company will use reasonable efforts to notify the Generator Owner prior to disconnecting.
- I. The Company will advise the Generator Owner with as much lead time as possible when the Generator Owner's Facility must be transferred from one Conectiv Power Delivery circuit to another circuit. The Company was also advise the Generator Owner of data on the Conectiv Power Delivery circuit needed by the Generator Owner to re-design or reset equipment at their Facility.

VIII. Technical Design Considerations

A. General

- 1) This Technical Considerations Document describes the minimum design requirements and operating procedures necessary for the safe and effective interconnection of parallel Customer owned generation. The Generator Owner's design must meet or exceed the requirements outlined in these Technical Considerations and also meet any applicable Tariff requirements. Some aspects of the Generator Owner's design and operation must also meet PJM, MAAC and NERC requirements.
- 2) The Customer's generation Facility must meet all applicable national, state and local municipal construction, safety and electrical codes. Company approval to interconnect indicates only that the minimum requirements for parallel operation outlined in this document have been satisfied. Such approval does not imply that the Generator Owner's Facility meets all federal, state and local standards and regulations.
- 3) All equipment, circuit breakers and other current interrupting devices at the Generator Owner's Facility must be capable of interrupting the maximum available fault current at the site including any contribution from the Facility's generator.
- 4) The Generator Owner must furnish and install a manual disconnect device which, when opened, will have the affect of isolating the generator from the Conectiv Power Delivery System. This disconnect device shall have a visual break such as a disconnect switch, a draw-out breaker, fuse block, etc. as appropriate to the voltage level. The disconnect device will, at all times, be accessible to Company personnel and be capable of being locked in the open position via a Company padlock. (The Company will use reasonable efforts to utilize padlocks of a size consistent with typical manufacturer's specifications.)

B. Background Information and Need for Protection

- 1) The Conectiv Power Delivery System is subject to a variety of natural and man-made hazards. Among these are lightning, wind, snow, animals, vehicular-pole accidents, vandalism and human error. These same hazards are present in residential and commercial electric systems but to a lesser degree due to the smaller size and protected environment of these systems.
- 2) The electric problems that can result from the preceding hazards are principally short circuits, grounded conductors and broken or open conductors. All of these problems require that the affected equipment be de-energized as quickly as possible to minimize equipment damage, to protect Grid security, to lessen the adverse impact on Customers and to remove any hazard to the public and Company personnel.
- 3) Before de-regulation, the Company owned and controlled all generation connected to the Grid. The Company had the full responsibility to install protective equipment to detect electrical problems and isolate the affected equipment. The interconnection of Customer owned generators in parallel with the Grid now expands this protection responsibility to include the Generator Owner. The Generator Owner has the responsibility to protect both his own Facility and the impact of his Facility on the Grid.

C. Basic Protection Goals

The protection system at the Point of Common Coupling should be designed and operated with the following desired goals in mind:

- 1) Protect the Conectiv Power Delivery System from the adverse impacts of the parallel generator.
- 2) Protect the parallel generator from faults or other disturbances in the Conectiv Power Delivery System.
- 3) Disconnect the parallel generator from the Conectiv Power Delivery System for abnormal operating conditions.
- 4) Permit the desired range of power transfer without false operation.

D. Protection General Requirements

- 1) The generator and Point of Common Coupling protection schemes shall be continuously monitored and in a functional state. The generator shall immediately be disconnected from the Company Grid for any condition that would make the protection scheme inoperable.
- 2) The operating power for the generator and Point of Common Coupling protection schemes and the control power used to disconnect the generator from the Company Grid must not be dependent on Company Grid power.
- 3) The generator protection shall be designed to automatically and immediately disconnect the generator from the Conectiv Power Delivery System if the source circuit from the Company is lost, irrespective of connected loads or other generators on the circuit.
- 4) The generator shall be equipped with protective equipment (hardware or software) to prevent the generator from energizing a de-energized Conectiv Power Delivery circuit.
- 5) Parallel operation must cease immediately and automatically for abnormal operating voltage, frequency, harmonic content or power flow. Parallel operation must also cease for loss of a phase or improper phase sequence. Voltage sensing shall be performed on all three phases.
- 6) Protection at the Point of Common Coupling must detect and isolate the Facility from the Conectiv Power Delivery System for a fault condition in the Generation Owner's Facility.
- 7) Protection at the Point of Common Coupling must detect and isolate from the Company Grid the Generation Owner's Facility for a fault condition on the Conectiv Power Delivery System circuit that supplies the generator site.
- 8) The protection scheme should permit the desired range of power transfer without false operation. The protection scheme should also prevent excessive or unnecessary tripping that would adversely affect the Company's service reliability to other Customers or Generator Owners.
- 9) The generator protection or protection at the Point of Common Coupling must insure that the generator is disconnected from the Company Grid before any automatic re-energizing of the Conectiv Power Delivery System supply circuit.

- 10) The protection at the Point of Common Coupling must recognize and disconnect the Generator from the Company Grid if the generator is Islandized with other Customer load. Exceptions are those generators with specific contractual obligations to supply other Customer load and who have installed necessary equipment to control and stabilize voltage and frequency within normal range within the Island.
- 11) Any automatic re-connection of the generator to the Grid following a loss and subsequent restoration of the Conectiv Power Delivery System source must occur only after the Company Grid has Stabilized.

Note: This preceding list of design requirements is not intended to be all-inclusive. Other hazards and conditions may need to be taken into consideration by the design engineer based upon the circumstances, the specific site, the Generation Owner's needs and other appropriate criteria.

E. Grid Interconnection Point Information

A Generator Owner will normally want to interconnect their generator to a Conectiv Power Delivery System circuit or power substation that is near their site. Some details on the Company Grid are noted below to assist the Generator Owner in the design of their Facility.

- 1) The Conectiv Power Delivery distribution system consists of 4kV, 12kV, 12.47kV, 23kV, 25kV and 34.5kV circuits. All 4kV, 12kV, and 12.47kV circuits are single ended, 4-wire grounded wye at the source end. The 25kV and 34.5kV circuits in the Conectiv Bay and New Castle Regions (Delaware, Maryland & Virginia) are also single ended, 4-wire grounded wye at the source end. The 23kV and 34.5kV circuits in the Conectiv Atlantic Region (New Jersey) are typically 3-wire circuits and may be singled ended or networked. All source ends are grounded wye.
- 2) The Conectiv Power Delivery transmission system consists of 69kV, 138kV, 230kV and 500kV circuits. The vast majority of Conectiv Power Delivery System transmission circuits are networked and all are grounded wye at a source end.
- 3) Not all delivery voltages are available at any particular location. The Company must be contacted for availability of specific delivery voltages for interconnection at a particular site.
- 4) The Conectiv Power Delivery System can only accept 60 Hz. alternating current from parallel generators. All AC generators within the size range covered by this document must be 3-phase.
- 5) The Company may limit the size of the generator that can be interconnected at any particular location due to the existing infrastructure and loading of the Grid surrounding the proposed generator site. Any Company Grid upgrades or new construction necessary to interconnect a generator larger than the existing Grid will support will be done at the Generator Owner's cost, unless otherwise allocated in accordance with PJM Tariff or PJM Operating Agreement.
- 6) The following table suggests the maximum generator size in MW that can be interconnected at the various Conectiv Power Delivery System voltage levels from both a practical and economic prospective. Some locations may not be able to support the value listed.

Table 1

Voltage Level	4kV	12kV	23/25kV	34.5kV	69kV	138kV	230kV
Max. Gen. Size (MW)	1.0	3.0	6.0	15.0	70.0	250.0	500.0

- 7) Most distribution and transmission lines have automatic line restoration following a line trip. The majority of faults (short circuits) are temporary in nature such as a flashed insulator or a tree limb that brushed against a line. Once the fault has been detected and the affected circuit de-energized, the circuit can normally be successfully re-energized. This re-energization or automatic reclose could occur after the line has been dead for 0.20 second, up to a minute or more. The net result of automatic line restoration is to restore the integrity of the Grid and to reduce any Customer outage time. The Generator Owner will have to take into account the impact of automatic circuit restoration in the design and operation of their Facility.

The Generator Owner may request the Company to delay any high speed reclosing on the Conectiv Power Delivery System supply circuit to allow the Parallel Operation generator sufficient time to remove itself from an islandized or de-energized circuit prior to automatic reclose. Since delaying the automatic reclose time degrades the level of service to other Customers on the circuit, the Company may limit any delay of the automatic reclose to a few seconds or less. Alternatively, the Generator Owner may request that a direct transfer trip scheme be added to remove the interconnected generator from service prior to automatic reclosing by using communication equipment between the Generator Owner's site and the Company. Similarly, the Generator Owner may request that a synchronizing check or reclose-blocking scheme be installed on the Company's source circuit to prevent out of phase reclosing. The Generator owner is responsible for all costs associated with the installation and maintenance of these requested modifications.

F. Interface Transformer

- 1) In most cases, an Interface Transformer will be required to interconnect the Generator Owner's Facility to the Conectiv Power Delivery System voltage. This Interface Transformer will decrease possible voltage variations seen by other Company Customers, attenuate any possible harmonics and reduces the effects of fault currents.
- 2) The Company reserves the right to specify the type of Interface Transformer connection (e.g. delta-delta, wye-delta, wye-wye) that should be utilized, consistent, where reasonable, with the needs of the Generator Owner's Facility. The intent here is to best integrate the transformer with the circuit grounding and area ground fault detection schemes.
- 3) In general, for generators in excess of 20 MW, or connected to the Company Grid at 138kV or higher voltage, or have authority to operate and carry other Customer load in an Islandized mode, the Interface Transformer shall have a grounded wye connection to the Company Grid.
- 4) An Interface Transformer that interfaces to the Company Grid with an ungrounded connection (delta or ungrounded wye) requires a special protection scheme to detect a grounded high side conductor. (See Protection Scheme Details, Section X - C, Table 6)
- 5) The Interface Transformer must be sized to support maximum anticipated power transfers to and from the Company Grid.
- 6) Interface Transformers up to 10 MVA can be fuse protected on the high side. Transformers larger than 10 MVA require a high side circuit breaker or circuit switcher along with appropriate protective relaying. (See Protection Scheme Details, Section X-B.)

G. Power Quality Considerations

- 1) The Generator Owner's Facility shall be designed and operated in such a manner that there are no noticeable adverse impacts to system voltage, frequency, harmonics etc.
- 2) The parallel generator shall not cause excessive voltage flicker on the Conectiv Power Delivery System. (Voltage flicker is defined as variations in system voltage magnitude and duration sufficient to allow visual observation of a change in electric light source intensity.) Any flicker shall not exceed the "Borderline of Irritation" Curve, Fig. 10.3, as defined in IEEE Std. 519-1992, *Recommended Practices and Requirements for Harmonic Control in Electric Power Systems*. The Company reserves the right to require tighter flicker control in situations where other Customer's equipment or operations (computers, instrumentation, process controls, etc.) are impacted.
- 3) The parallel generator could introduce harmonics distortion into the Company Grid if equipment such as DC to AC inverters are used in the Facility. (Harmonic distortion is defined as continuous distortion of the normal 60 Hz. sine wave typically caused by non-linear loads or by inverters, measured in total harmonic distortion, THD.) Any voltage harmonic distortion shall not exceed the limitation as defined in IEEE Std. 519-1992, *Recommended Practices and Requirements for Harmonic Control in Electric Power Systems*, Table 11.1. The limits vary dependent on the voltage. In addition, the level of harmonic current that the Generator Owner shall inject into the Company Grid should not exceed the level specified in Table 10.3 in IEEE Std. 519-1992.
- 4) Any DC to AC inverter should not inject DC current greater than 0.5% of the rated inverter capacity into the Point of Common Coupling during both normal and abnormal operation.

H. Power Factor Considerations

- 1) A parallel generator shall not adversely impact the power factor of the Conectiv Power Delivery System at or near the Point of Common Coupling. The generator type impacts the power factor. The inverters of most DC generators are designed to operate close to unity power factor. Induction generators absorb vars from the Conectiv Power Delivery System. Synchronous generators can either absorb or produce vars thus having a varying power factor depending upon excitation control.
- 2) Synchronous generators shall have and maintain a minimum design capacity to operate at a power factor between 0.9 to 1.0 lagging (supplying Vars to the Conectiv Power Delivery System).
- 3) Synchronous generators shall be operated so as not to absorb vars from the Conectiv Power Delivery System unless directed by the System Control Center. In certain cases, larger units will be required to have and maintain a minimum design capacity to operate at a power factor between 0.95 and 1.0 leading (absorbing Vars from the Conectiv Power Delivery System). These requirements will be discussed on a case-by-case basis.
- 4) The dispatching authority can request that the generator real and reactive power output be adjusted to best meet the needs of the overall Grid.
- 5) Depending on the Point of Common Coupling location, the Conectiv Power Delivery System can be limited in the amount of reactive power capacity available to the Generator Owner. The Generator Owner must provide for his own reactive power requirements (via generator control, capacitors, etc.) so as to operate at no less a power factor (drawing vars from the Conectiv Power Delivery System) at the Point of Common Coupling than existed prior to the

installation of the Facility. Any reactive power requirements in excess of this limit may require upgrades and/or the installation of capacitor units on the Conectiv Power Delivery System. The costs for any such upgrades will be charged to the Generator Owner. Specific purchase power arrangements, including power factor requirements, are defined in appropriate tariffs and interconnection agreements.

- 6) In general, to avoid control interaction with the Conectiv Power Delivery System voltage regulating equipment, those generators interconnected with Conectiv Power Delivery System distribution circuits at 34.5kV and below, shall have automatic excitation control systems which are designed to provide constant power factor or var flow rather than control voltage.

I. Inverter Considerations

- 1) Photovoltaic, fuel cell and wind DC generation sources could fall within the lower range of parallel generator sizes covered by this Technical Consideration document. These sources of DC generation will utilize inverters to convert their DC output to AC power acceptable to the Grid.
- 2) The Generator Owner must use a non-islanding type inverter as defined in IEEE 929 2000, *IEEE Recommended Practices for Utility Interface of Photovoltaic (PV) Systems* and UL Subject 1741, May 1999, *Standard for Static Inverters and Charge Controllers for use in Photovoltaic Power Systems*.
- 3) Non-islanding type inverters are inherently designed to automatically disconnect from the Grid if the Generator Owner's site becomes isolated from the Conectiv Power Delivery System. This type inverter also prevents the Generator owner from inadvertently supplying other Company Customers in an isolated Island situation.
- 4) The inverter output specifications must meet the power quality considerations detailed in Section VIII - G.

J. Induction Generator Considerations

Wind and other generation sources utilizing induction generators, singularly or in aggregate, could fall within the lower range of parallel generator sizes covered by this Technical Consideration document.

- 1) The reactive supply for induction generators may impose some design and generator size constraints as these generators obtain their excitation from the Grid. Capacitors may have to be added either at the Generator Owner's site or on the Conectiv Power Delivery System. (See Section VIII - H) The addition of capacitors may also cause undesirable ferroresonance.
- 2) Any flicker produced in the course of starting an induction generator and bringing it up to synchronous speed (as an induction motor) must not exceed the flicker limit detailed in Section VIII - G 2.
- 3) The installation of capacitors for reactive supply at or near a induction generator site greatly increases the risk that the induction machine may become self-excited if somehow isolated from the Grid. A self-excited induction generator can rapidly produce abnormally high voltages which can damage equipment on the Grid and at other Customer sites. Self-excitation is more likely where the Grid capacity and the circuit load density are both low.

- 4) The Generator Owner with an induction generator must include protection at their facility to detect self-excitation operation and disconnect the generator from the Conectiv Power Delivery System.
- 5) By their design, induction generators can only supply fault current for a short period of time as the field flux decays rapidly on removal or decay of the source voltage.

K. Synchronous Generator Considerations

- 1) By their design and generally larger size, synchronous generators are capable of supporting sustained fault currents. As such, the protection scheme associated with the Point of Common Coupling must be designed to insure detection of fault conditions in the Conectiv Power Delivery System.
- 2) Synchronous generators are capable of operating independently irrespective of the Grid source. They can continue to operate after being isolated from the Grid providing the load is within the generator's capacity. Consequently, a more robust protection scheme is generally needed to detect isolation from the Grid, such as transfer trip from the Company source.
- 3) Sufficient generator reactive power capability shall be provided to withstand normal voltage changes on the Conectiv Power Delivery System.

L. Interval (Revenue) Metering Considerations

Detailed kilowatt-hour metering requirements are outside of the scope of this document. The requirements for each parallel generator installation will be reviewed and determined on a case-by-case basis. Listed below are the most common requirements for generator interval metering, however, the Company reserves the right to specify the required interval metering equipment for each paralleled generator site.

- 1) All paralleled generator Facilities shall be metered in accordance with applicable tariffs and specifications provided in approved Company publications.
As a minimum, the following interval data is required:
 - MWhr and MVARhr Output for Each Generator
 - MWhr and MVARhr Input/Output at the Point of Interconnection
- 2) There shall be interval metering for the net output of each generator. However, multiple generators may be reported as a single unit for total generation up to 10 MW at a given facility.
- 3) Interval Data requires the Generator Owner to supply a data recorder and telephone line which allows the Company to dial up and retrieve the interval data remotely. Specific requirements will be determined on a case-by-case basis.
- 4) Generator interval metering is not required for facilities which have no load (i.e. residential, commercial or industrial) under retail tariffs (including standby agreements), exclusive of station auxiliary power consumption.
- 5) Unless otherwise mutually agreed upon by the Company and the Generator Owner, the Company shall have ownership of the equipment and supply all inspection, reading, maintenance and testing of interval metering for the Generator Owner's Facility, at the Generator Owner's cost. The Company may elect to have the Generator Owner install the

metering PTs (potential transformers) and CTs (current transformers) within the Generator Owner's switchgear equipment.

- 6) The Company shall require interval metering of the generator output to the extent reasonably necessary to provide the Company with the data needed to administer its tariffs and to operate and plan the Conectiv Power Delivery System.
- 7) The Point of Common Coupling interval metering shall be bi-directional so that power deliveries to and from the Generator Owner's site can be separately recorded. The Point of Common Coupling metering shall be equipped with detents to prevent reverse registration.
- 8) The Generator Owner may, at its sole option and cost, install or have the Company install additional metering equipment to meet any special needs that the Generator Owner may have.

M. Monitoring and Control Considerations

Since parallel generators, particularly the larger units, have a direct impact on the overall operation and performance of the Grid, it is important that the Company monitor and, in some cases, have control access to generator synchronizing and interface breakers. In addition, monitoring and certain control functions are needed for those parallel generators that are dispatched by the Company. The requirements for each parallel generator installation will be reviewed on a case-by-case basis. However, some basic assumptions can be made.

- 1) The Generator Owner shall purchase and install a Remote Terminal Unit (RTU) of a suitable vendor to enable the Company and, if required, PJM to monitor the status of the data points listed in item 6) below at the Generator Owner's site and to control certain breakers, if required. This RTU shall utilize DNP 3.0 protocol, or other such protocol compatible with the existing Supervisory Control System at the Company.
- 2) The Generator Owner shall provide a communication link between the Company and, if required, PJM and the Generator Owner's on-site RTU.
- 3) For the Generator Owner's RTU communication with the Company, a dedicated communication path is necessary to provide real time data. (The Company's Supervisory Control System will not presently accept dial up or "communicate when necessity" operation.)
- 4) RTU requirements will vary based on the size of installed generation. Analog telemetry and status indication points are listed below. In addition, certain control functions may be required to allow remote dispatch of generation or isolation of the generator from the Conectiv Power Delivery System in the event of System Emergencies. Specific requirements will be determined on a case-by-case basis.
 - Units 1 MW to 10 MW Capacity
 - a) Telemeter total generation MW and MVAR Output, MWhr and MVARhr for each generator.
 - b) Telemeter Point of Interconnection MW, MVAR, Amp Flow on each Point of Interconnection.
 - c) Telemeter generation and Point of Interconnection Bus Voltages
 - d) Status indication of generator breaker(s) and Point of Interconnection breaker/switch.
 - e) RTU interconnection to Company.

- Units 10 MW to 50 MW Capacity
 - a) Telemeter MW and MVAR Output, MWhr and MVARhr for each generator.
 - b) Telemeter MW, MVAR, Amp Flow, MWhr and MVARhr on each Point of Interconnection.
 - c) Telemeter generation and Point of Interconnection Bus Voltages.
 - d) Telemeter frequency at the Point of Interconnection.
 - e) Status indication of generator breakers and Point of Interconnection breakers.
 - f) RTU interconnection to Company required.

- Units 50 MW to 500 MW Capacity
 - a) Telemeter MW and MVAR Output, MWhr and MVARhr for each generator.
 - b) Telemeter MW and MVAR load of generator auxiliaries and Facility.
 - c) Telemeter MW, MVAR, Amp Flow, MWhr and MVARhr on each Point of Interconnection.
 - d) Telemeter MW, MVAR, Amp Flow through Interface Transformer if loading is different than generator .
 - e) Telemeter generation and Point of Interconnection Bus Voltages
 - f) Telemeter frequency at the Point of Interconnection.
 - g) Status indication of generator breakers and all substation breakers
 - h) RTU interconnection to Company via dual communication paths required

Note 1: The Generator Owner shall contact PJM directly and review PJM documents to insure compliance with all the PJM RTU monitoring/control requirements for their proposed site.

Note 2: The Company will allow multiple generator unit data to be combined into a single unit for Facilities not exceeding 10 MW total generation for all units.

N. Event Recording Considerations

- 1) The Generator Owner shall purchase and install recording equipment to monitor the performance of their protection and control equipment for those parallel generator sites interconnected with the Conectiv Power Delivery System at voltages 69kV and above.
- 2) The Company reserves the right to specify the voltages, currents, device status, etc. to be monitored and recorded by this event recording equipment.
- 3) Event information may be recorded by features internal to microprocessor type protective relays, by separate digital fault/event recorders or by a combination of these two methods.
- 4) When a digital fault/event recorder is installed, the Company will specify a manufacturer and type to insure compatibility with other digital fault/event recorders in the Conectiv Power Delivery System.
- 5) The Company shall have remote access to any recorded information for use in analyzing the performance of the overall electric Grid.
- 6) The Generator Owner will supply a dialup telephone line for the event recording equipment for remote access of the data.
- 7) PJM requires that separate fault recording devices be installed at major 230kV substations and all generating stations with a total generation capacity of 500 MW or above. The Generator

Owner should review the *PJM Protective Relaying and Design Philosophy Standards, Appendix B*, for a tabulation of desired quantities to be recorded on these fault recorders.

- 8) Digital fault recorders should be time synchronized to a reference traceable to the National Institute of Standards and Technology.

IX. Performance Considerations

A. General

- 1) The interconnection of parallel generation with the Conectiv Power Delivery System is permissible only if the system voltage, frequency and current flow at the Point of Common Coupling are within normal limits. Parallel operation must cease immediately and automatically for abnormal voltage, frequency, or current flow as defined below.
- 2) Parallel operation must also cease automatically for operation outside the power quality limitations detailed in Technical Design Considerations, Section VIII - G.

B. Voltage Limits

- 1) The Generator Owner's equipment shall be operated in such a manner that the voltage levels on the Company's Grid remain within the operating limits defined by ANSI C84.1.
- 2) The generator must immediately and automatically cease parallel operation and disconnect from the Conectiv Power Delivery System if the voltage at the Point of Common Coupling exceeds the limits defined below:

Table 2

DC Generating Systems with Non-Islanding Inverters	Induction and Synchronous Generators All Sizes
a) Trip in 0.1 Second for $V < 50\%$ b) Trip within 0.1 to 30 Seconds for $50\% \leq V < 88\%$ c) Trip within 0.1 to 30 Seconds for $106\% < V < 137\%$ d) Trip in 0.03 Second for $137\% \leq V$ (Specific voltage and time delay set points will be determined for each generator installation)	a) Trip in 0.1 Second for $V \geq 115\%$ b) Trip within 0.1 to 30 Seconds for $V > 110\%$ or $V < 90\%$ (Specific voltage and time delay set points will be determined for each generator installation.) Note: Exceptions to these limits are those bulk generators with a contractual obligation and authority to supply other Customer load in an island mode arrangement, and which have installed appropriate equipment to control and stabilize voltage within the island.

Notes:

- i. Trip time refers to the time between when the abnormal voltage condition occurs and the generator being disconnected from the Company Grid.
 - ii. Three-phase voltage sensing shall be used.
 - iii. The voltages must be sensed on the high side of any Interface Transformer if the high voltage winding is ungrounded. Such a scheme is necessary to rapidly detect severe overvoltages that occur for a grounded high side conductor being energized from an ungrounded generation source. These high voltages can quickly cause catastrophic failure of lightning arresters and lead to other equipment insulation failures.
- 3) The Generator Owner may reconnect to the Grid when the system voltage returns to normal range and the Grid is Stabilized. Reconnection approval shall be requested from Company System Control Center.

C. Frequency Limits

- 1) The generator must immediately and automatically cease parallel operation and disconnect from the Conectiv Power Delivery System if the operating frequency exceeds the limits defined below:

Table 3

DC Generating Systems With Non-Islanding Inverters	Induction/Synchronous Generators Non PJM Market Up to 10 MW	Synchronous Generators In PJM Market or Greater than 10 MW
a) Trip in 0.1 Second for F < 59.3 Hz. b) Trip in 0.1 Second for F > 60.5 Hz. (Set points taken from IEEE Std. 929.)	a) Trip in 0.1 Second for F < 59.3 Hz. b) Trip in 0.1 Second for F > 60.5 Hz. (Other frequency and time delay set points may be necessary for a specific installation.)	a) Trip in 5.0 Seconds for F < 57.5 Hz. b) Trip within 1.0 Second for F > 61.0 Hz.

Notes:

- i. Trip time refers to the time between when the abnormal frequency condition occurs and the generator being disconnected from the Company Grid.
- ii. Synchronous Generators less than 10 MW whose output is netted with peak load (net system load reducer) to calculate PJM underfrequency load shedding needs, will also have to meet frequency requirements for PJM Market generators.
- iii. PJM Frequency requirements are to provide uniformity across the entire Grid and to insure that all generator units will remain online until the frequency limits are reached.
- iv. PJM can grant an exception to the trip frequency requirement if warranted.

- 2) The Generator Owner may reconnect to the Grid when the system frequency returns to normal range and the Grid is Stabilized. Reconnection approval shall be requested from the Company System Control Center.

D. Synchronization

- 1) In order to avoid damaging a generator during synchronizing, the generator manufacturer will generally provide synchronizing limits in terms of breaker closing angle, slip frequency and voltage matching. Those manufacturer limits should be followed but in no case should they exceed the limits listed below.

Table 4

Frequency Difference (Slip)	Voltage Difference	Phase Angle Difference
0.2 Hz.	10%	10 Degrees

- 2) Generators with a Stiffness Ratio of 20 or less, or those units where a stability study has indicated possible unstable operation shall be equipped with a protective functions suitable for detecting loss of synchronism (out of step or pole slipping).
- 3) Induction generators that are started across the line shall not cause voltage flicker to exceed the limitation defined in Technical Design Considerations, Section VIII - G 2. If these flicker

limits are exceeded, the induction generator shall be accelerated to synchronous speed by the prime mover prior to paralleling with the Company Grid.

- 4) The inverters of DC generating systems shall obtain their commutation reference from the Company Grid and thus synchronization will not be an issue.

E. Island Operation

- 1) The generator must automatically and immediately disconnect from the Conectiv Power Delivery System if the source from the Grid is lost. This separation must occur irrespective of connected load or other generators on the circuit. Islandizing of Customer owned generation with other Customers will be permitted only if specific contractual arrangements have been made and necessary equipment has been installed by the Generator Owner to control and stabilize the island voltage and frequency within the limitations defined in Sections IX - B and C. In general, this will require the Interface Transformer to provide a grounded source to the Island and a generator capable of isochronous operation.
- 2) The generator must be disconnected from the Company Grid before any automatic reclose or re-energization of the Company source.

F. Fault Detection and Isolation

- 1) For a fault condition on the Company source circuit that interconnects with the Generator Owner's Facility, the Generator Owner must have protective relaying to detect this condition and disconnect the generator from the Grid. The required operating time of the protection scheme is dependant on many variables such as voltage class, generator stability concerns, primary vs. backup relaying, coordination requirements with Company relaying scheme, etc. The Company will work with the Generator Owner and ascertain the performance requirements on a case by case basis.
- 2) In cases where clearing time from the Generator Site is critical, transfer trip from the Company end of the circuit to the Generator Owner's site may be required.
- 3) For a fault condition within the Generator Owner's Facility, the Generator Owner must have protective relaying to detect and isolate the fault from the Conectiv Power Delivery System. The required clearing time of the Facility's protection schemes is dependent on many variables such as voltage class and the operating time of any Company protection schemes that reach into the Facility. The Company will review the proposed operating time of the Facility's protection schemes and ascertain the performance requirements on a case by case basis.

G. Closed Transition Switching Installations

Some privately owned generation may be paralleled only momentarily with the Conectiv Power Delivery System during part of a source or load transfer sequence.

- 1) At the time of momentary parallel operation, these installations must meet the voltage, frequency and synchronization requirements outlined in preceding Sections IX - B, C, and D. The synchronizing may be manual for generators up to 10 MW if the closed transition is manually initiated. Otherwise, the synchronizing should be automatic.

- 2) The transition scheme must have an additional safeguard to limit the amount of time the generator is paralleled with the Grid. The scheme shall trip the generator if the closed transition mode remains in effect longer than some predetermined time, usually 0.1 second.

X. Protection Scheme Details

A. General

- 1) The protection schemes described in this section are intended to be typical for illustration purposes and not specific design requirements for any particular site. They are intended to guide the proposed Generator Owner as to the type of protection schemes necessary for Parallel Operation generation.
- 2) Protective relays, wherever possible, shall be microprocessor type with integral trip record and fault recording, self-checking and remote communications. Remote communications should be provided through a digital switching device to allow a single communication line to service multiple protective relays.
- 3) All protective relays must have the desired sensitivity and speed for its intended application and be of utility grade. The Company can provide feedback to the Generator Owner in this regard.
- 4) All equipment, lines and busses operating at 69kV and above shall be protected by two independent protective schemes.
- 5) Primary and backup protection schemes shall be supplied via independent current/potential circuits and independently protected DC control circuits.
- 6) DC circuits supplying protective relaying schemes shall be continuously monitored and fused separately from any other DC control circuits. Loss of any control power bus including DC trip and close busses of each breaker shall also be monitored and alarmed to a manned location so that corrective action can be taken. Relay failure alarms shall be handled in a similar manner.
- 7) Generator units selling into the PJM marketplace, or interconnected at 230kV and above, must meet the protection requirements detailed in the *PJM Protective Relaying Philosophy and Design Standards* document.
- 8) All protective relay systems, equipment, design, operation and maintenance shall be in accordance with all applicable Federal, State and Local requirements, National and Regional Reliability Criteria and Industry Recognized Standards and Guidelines. References to such requirements may be found in Section XIII of this document. The listing is not intended to be all-inclusive.

B. Interface Transformer Protection

Typical protection schemes for various size Interface Transformers are illustrated below.

Table 5

Up to 10 MVA	10 – 50 MVA	Greater than 50 MVA
<ul style="list-style-type: none"> • High Side Fuse (4kV, 12kV, 23kV, 25kV, 34.5kV or 69kV only) 	<ul style="list-style-type: none"> • Transformer Differential • Fault Pressure • Time/Inst. Overcurrent 	<ul style="list-style-type: none"> • Transformer Primary Differential • Transformer Backup Differential • Fault Pressure • Time/Inst. Overcurrent • Overexcitation

Notes:

- i. For transformers needing two differential protection schemes, one of the differential schemes may also include the generator.
- ii. The location of the transformer overcurrent relaying may be dependent on the transformer connections.
- iii. Generators with a fuse protected Interface Transformer must include protection to detect an open fuse condition.

C. Interconnection Line Protection

The protection applied to a line terminal at the Generator Owner’s site that interconnects the privately owned generator with the Conectiv Power Delivery System will vary depending on the voltage class and existing line relaying scheme at the Company end(s).

Typical protection schemes for various voltage interconnection lines are provided below. The actual schemes used will vary for each specific site.

Table 6

Line Voltage Class	Possible Line Protection Schemes
4kV & 12kV	<ul style="list-style-type: none">• Phase & Ground Overcurrent (May need to be directional)• Overvoltage supplied via broken delta Aux. PT or 3-phase Overvoltage (For line terminating in delta connected transformer)
23kV, 25kV, 34.5kV	<ul style="list-style-type: none">• Phase & Ground Overcurrent (May need to be directional)• Overvoltage supplied via broken delta Aux. PT or 3 Phase Overvoltage (For line terminating in delta connected transformer)
69kV	<ul style="list-style-type: none">• Phase & Ground Directional Overcurrent• Phase & Ground Distance Pilot (Directional Comparison, POTT, PUTT, DTT)• Phase & Ground Step Distance Backup• 3 Phase Overvoltage (For line terminating in delta connected transformer)
138kV	<ul style="list-style-type: none">• Phase & Ground Distance Pilot (Directional Comparison, POTT, PUTT, DTT)• Phase & Ground Step Distance Backup• Direct Transfer Trip Send/Receive
230 & 500kV	<ul style="list-style-type: none">• Phase & Ground Distance Pilot (Directional Comparison, POTT, PUTT, DTT)• Phase & Ground Step Distance Backup• Direct Transfer Trip Send/Receive

Notes:

- i. Generators that can go unstable if line pilot protection scheme fails, resulting in delayed fault clearing, will require two independent high speed pilot schemes, with independent communication channels.
- ii. POTT is Permissive Overreaching Transfer Trip
- iii. PUTT is Permissive Under Reaching Transfer Trip.
- iv. DTT is Direct Transfer Trip

D. Generator Isolation Detection Schemes

- 1) Under/over frequency and under/over voltage schemes can be used to detect the fact that the generator is Islanded with load (and possibly other generation) and needs to be disconnected from the Company Grid. These schemes are effective where there is a significant mismatch between load and generator rating. (See Performance Considerations, Sections IX - B3 and C1)
- 2) Under/over frequency and under/over voltage detection becomes less reliable when the Islanded load is closely matched to the generator capacity so that the resulting voltage and frequency is at or very near normal. In these cases, direct transfer trip from the Conectiv Power Delivery System end of the interconnection circuit will be necessary.
- 3) Generators selling into the PJM marketplace that have their under frequency trip point set to 57.5 Hz. for 5 seconds essentially removes under frequency sensing as a sensitive means to detect isolation. In this event, other protective measures may be required.
- 4) Generally, combinations of different protection schemes are necessary to be 100% effective and to provide a level of redundancy.

E. Generator Protection Schemes

- 1) The protection schemes on generators will become more complex as the size of the generator unit increases. In addition, those generators selling into the PJM marketplace will require specific protection as required by PJM.
- 2) Multi-function microprocessor relays can be used to provide several generator protection functions. However, a second multi-function relay (preferably from another manufacturer to avoid a common failure mode or defective algorithm) is necessary to provide for a relay failure. Alternatively, the generator could be immediately and automatically tripped off line upon a relay failure alarm and remain off line until the relay is repaired. This arrangement, however, may jeopardize the Generator Owner's ability to sell firm capacity into the PJM marketplace.
- 3) The Generator Owner should consult the generator manufacturer and national standards to develop the appropriate protection for each generator installation. National standards include C37.102-1987 (Reaff 1990) *IEEE Guide for AC Generator Protection* and C37.101-1985 *IEEE Guide for Generator Ground Protection*.
- 4) Installations larger than 100 MW will have to meet the generator protection requirements of the *PJM Protective Relaying Philosophy and Design Standards*.
- 5) Some typical protection schemes for various size generators are noted below. The actual schemes required for each site could vary from these representative samples.

Table 7

DC Generating Systems With Non-Islanding Inverters	Induction/Synchronous Generators Up to 10 MW	Synchronous Generators 10MW up to 50 MW	Synchronous Generators 50 MW & Above
<ul style="list-style-type: none"> • Over/Under Voltage • Over/Under Freq. <p>(This protection is integral to the Non-Islanding Inverter.)</p> <ul style="list-style-type: none"> • DC Overcurrent 	<ul style="list-style-type: none"> • Over/Under Voltage • Over/Under Freq. • Directional Power (watt / var) • Phase Overcurrent • Ground Overcurrent • Negative Sequence 	<ul style="list-style-type: none"> • Over/Under Voltage • Over/Under Freq. • Differential • Stator Ground • Loss of Field • Anti-Motoring • Negative Sequence • Voltage Controlled. Overcurrent 	<ul style="list-style-type: none"> • Over/Under Voltage • Over/Under Freq. • Primary Differential • Back Up Differential • 100% Stator Ground • Back Up Stator Ground • Generator Lead Protection • Primary Loss of Field • Back Up Loss of Field • Field Ground • Anti-Motoring • Negative Sequence • Voltage Controlled Overcurrent or Distance Backup • Breaker Flashover • Protection During Unit Start Up & Shut Down • Accidental Energization • Out of Step Protection • Synchronizing Check <p align="center">(Ref. Appendix A)</p>

Comments

- a) On generators with primary and backup differentials, one differential may also cover the unit step up transformer.
- b) Additional PJM requirements will apply for units 100MW and above or that are interconnected at 230kV and above.
- c) Loss of synchronism (out-of-step) protection is necessary where stability studies have shown this protection to be needed.
- d) Ancillary protection schemes such as breaker failure are also required.

XI. Typical One-Line Diagrams

These One-Line Diagrams are intended to be typical or representative samples of various types and sizes of generation Facilities that are connected to and operate in parallel with the Conectiv Power Delivery System. Each site will have to be specifically designed taking into account the unique characteristics of each installation, the specific location of the interconnection point and the operating and contractual requirements for that site. Additional PJM and MACC requirements may also apply.

Figure 1, Typical DC Generator with Non-Islanding Inverter

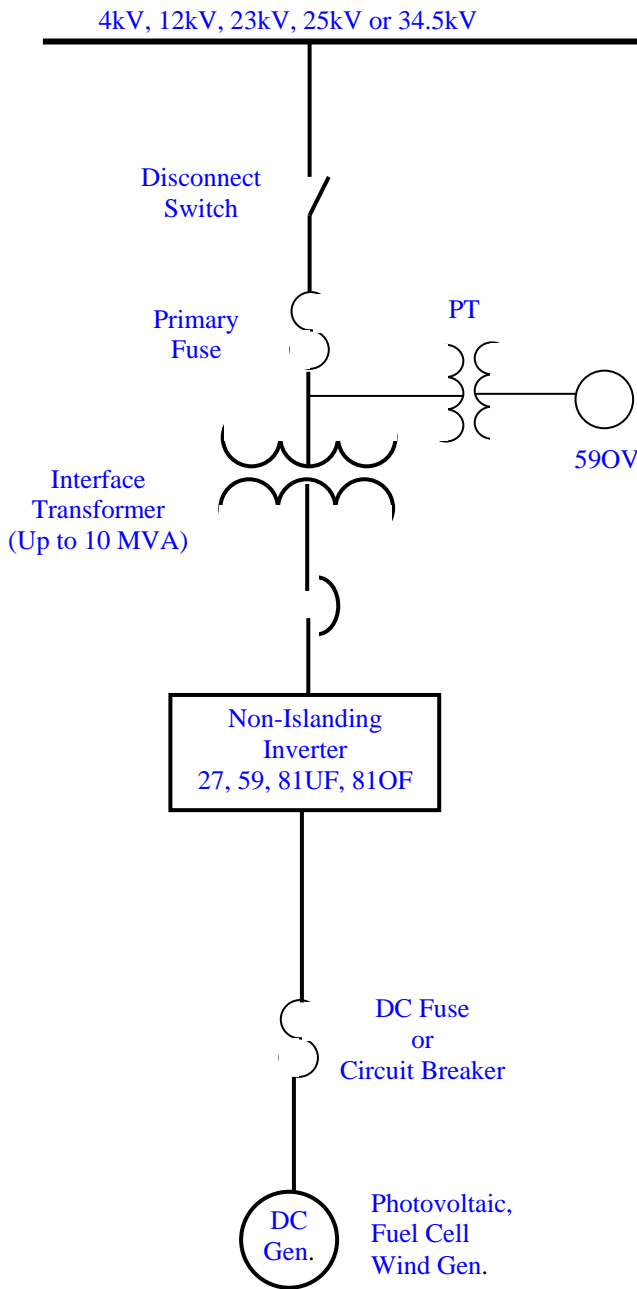

Device Designations & Function	
27	– Undervoltage Protection
59	– Overvoltage Protection
81UF	– Underfrequency Protection
81OF	– Overfrequency Protection

The above protection functions are integral to the Non-Islanding Inverter and are used to monitor the output of the inverter and to detect when the DC Generating Facility has been isolated from the power Grid. An operation of any protective function will disconnect the generating Facility from the Grid

59OV - Overvoltage Protection

This is necessary where the high side of the Interface Transformer is connected ungrounded wye or in delta. The relay is used to detect a grounded high side conductor. Relay operation will shut down the inverter.

Three, phase-to-ground connected relays or one relay connected across an open delta PT secondary is needed in this application.

Figure 2, Typical AC Induction or Synchronous Generator Up to 10 MW

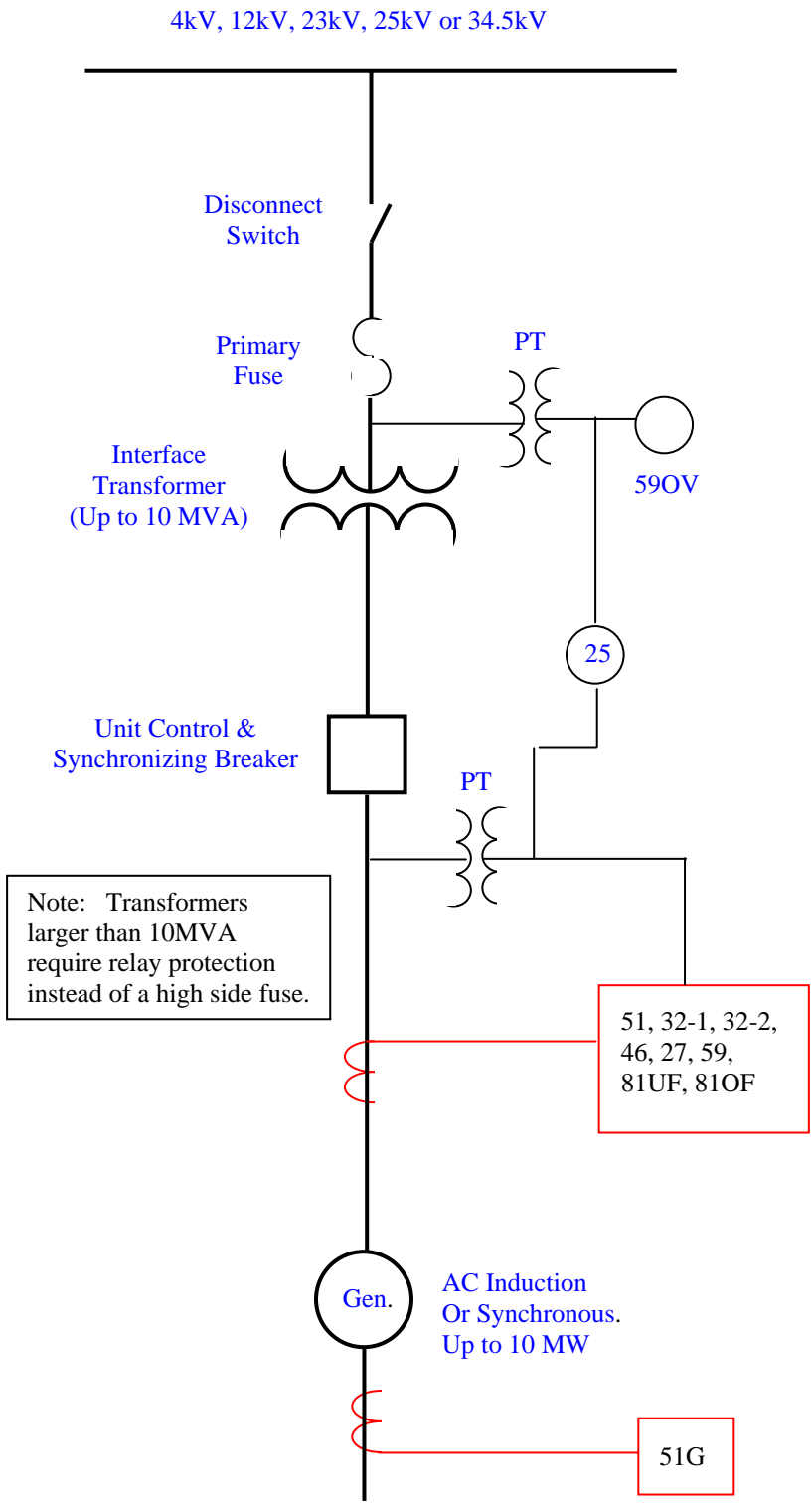

Connection Point Limits	
4kV	- Up to 1 MVA
12kV	- Up to 3 MVA
23/25kV	- Up to 6 MVA
34.5kv	- Up to 15 MVA

Device Designation & Function	
27	- Undervoltage Protection
59	- Overvoltage Protection
81UF	- Underfrequency Protection
81OF	- Underfrequency Protection
The above protection functions monitor the output of the generator and detect when the Generating Facility has been isolated from the Grid.	
25	- Synchronism Check Relay
590V	- Overvoltage Protection
This relay is necessary where the high side of the Interface Transformer is connected ungrounded wye or delta. The relay is used to detect a grounded high side conductor. Three, phase-to-ground connected relays or one relay connected across an open delta PT secondary is needed in this application.	
46	- Negative Sequence Protection
Protects against a blown high side fuse or an open phase conductor.	
51	- Time Overcurrent Protection
Provides backup protection for phase faults in the Transformer or the Grid.	
51G	- Ground Time Overcurrent
Protects against a stator ground fault condition in the generator.	
32-1, 32-2	- Power Directional Relays
One protects against loss of the prime mover and the generator acting like a motor. A second 32 relay is used to limit power exported to the Grid.	

Figure 3, Typical AC Synchronous Generator Up to 50 MW

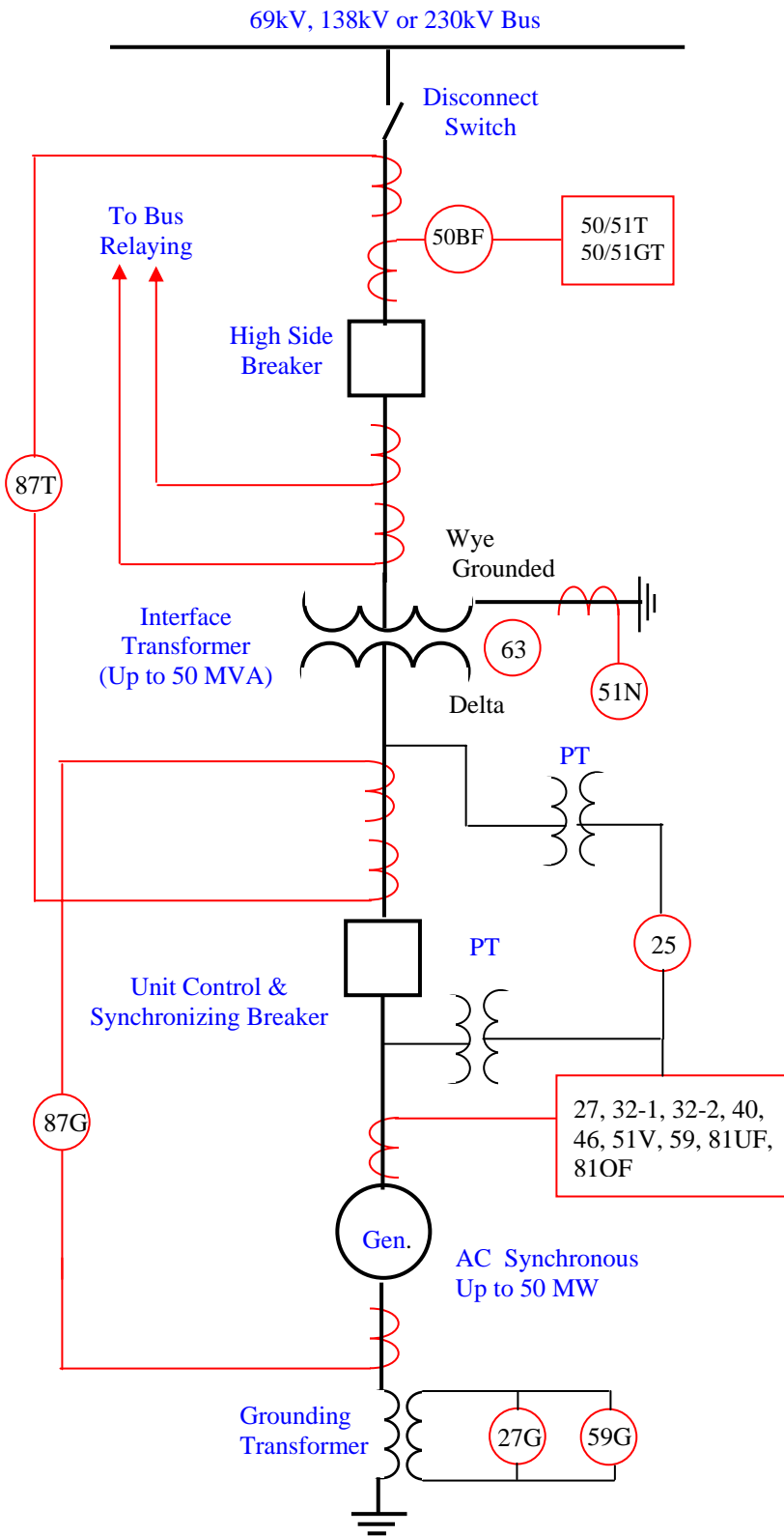

Device Designation & Function

- 27** - Undervoltage Protection
- 59** - Overvoltage Protection
- 81UF** - Underfrequency Protection
- 81OF** - Underfrequency Protection
- The above protection functions monitor the output of the generator and detect when the Generating Facility has been isolated from the Grid.
- 25** – Synchronism Check Relay
- 32-1, 32-2** - Power Directional Relays
- One protects against loss of the prime mover and the generator acting like a motor. A second 32 relay is used to limit power exported to the Grid.
- 40** – Generator Loss of Field Detection
- 46** - Negative Sequence Protection
- Protects against an open phase conductor.
- 50BF** - Breaker Failure Protection
- 51N** - Overcurrent Ground Relay to provide backup protection for system ground faults.
- 51V** - Voltage Supervised Time Over-current Protection
- Provides backup protection for phase faults in the Transformer or the Grid.
- 27G**
- 59G** - Generator Stator Ground Fault
- Protection Relays the combination of which covers 100% of the stator winding.
- 63** - Transformer Sudden Pressure Relay
- 50/51T** - Phase Overcurrent Relay
- 50/51GT** - Ground Overcurrent Relay
- Provides backup protection for the Interface Transformer.
- 87G** – Generator Differential Protection
- 87T** – Transformer Differential Protection

Figure 4, Typical AC Synchronous Generator, 51 MVA or Greater (Ref. Appendix A for details)

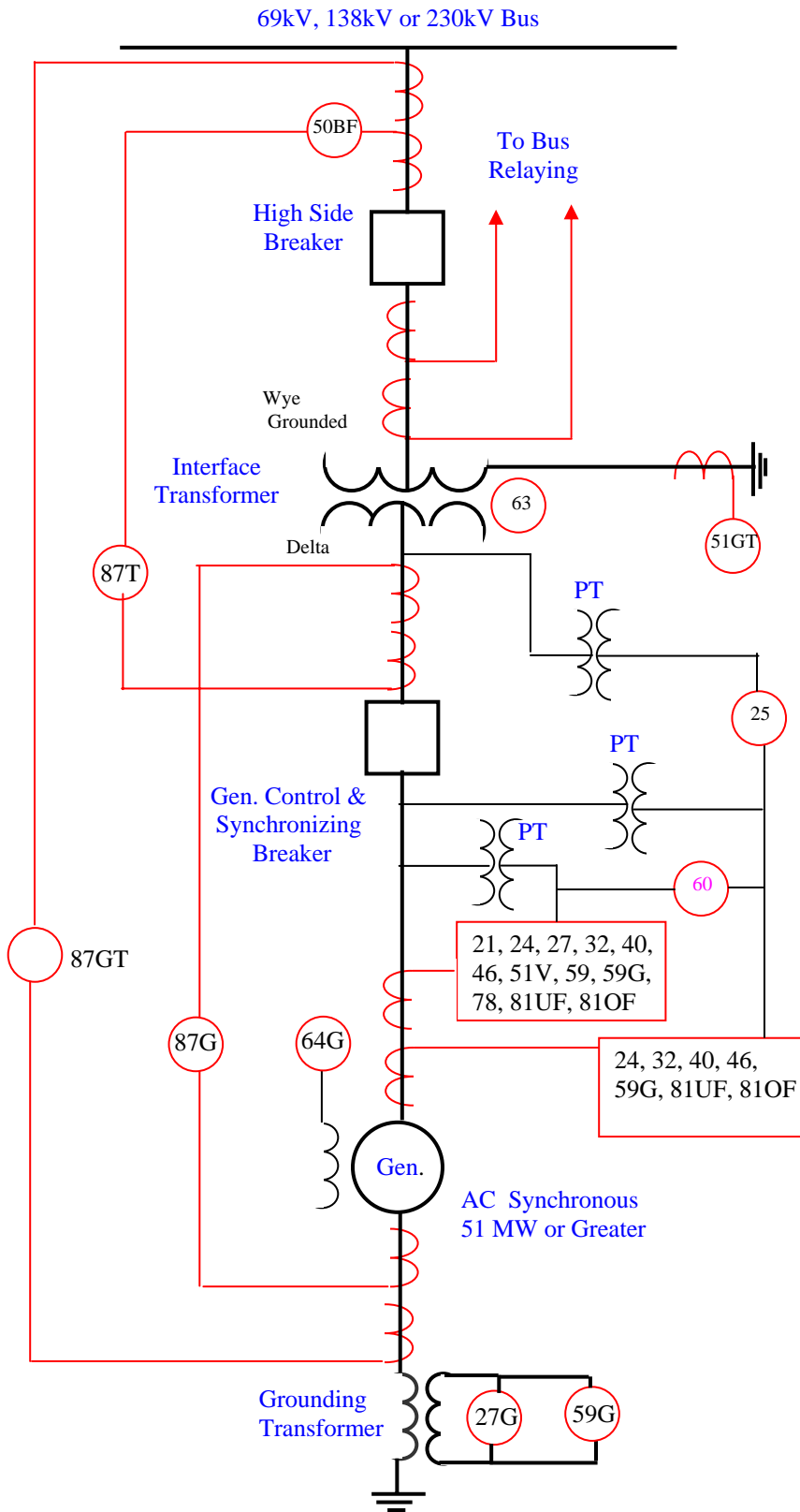

Device Designation & Function

- 27** - Undervoltage Protection
- 59** - Overvoltage Protection
- 81UF** – Underfrequency Protection
- 81OF** - Underfrequency Protection
- The above protection functions monitor the output of the generator and may assist to detect when the Generating Facility has been isolated from the Grid.
- 21** - Phase Distance Relay
Provides supplemental protection for external faults.
- 24**- Overexcitation / Volts per Hertz
- 25**- Synchronism Check Relay
- 27G**
- 59G** – Generator Stator Ground Fault protection relays, the combination of which covers 100% of the stator winding
- 32** - Generator Anti-Motoring Relay
Protects against loss of the prime mover and the generator acting like a motor.
- 40** - Generator Loss of Field Detection
Detects loss of field or regulator failure.
- 46** - Negative Sequence Protection
Protects against unbalance currents such as caused by an open phase conductor.
- 51GT** - Ground Overcurrent Relay
Provides backup protection for external Grid ground faults.
- 51V** - Voltage Supervised Time Over-current Protection
Provides backup protection for phase faults in the Transformer or the Grid.
- 60** - Voltage Balance Relay
- 63** - Transformer Sudden Pressure Relay
- 64G** - Generator Field Ground Relay
Detects shorts in the generator field winding.
- 78** - Out-of-Step Protection
- 87G** - Generator Differential Protection
- 87GT** - Generator and Transformer Overall Differential Protection

Figure 5, Typical Sample of High Voltage Interface Substation, Straight Bus Configuration

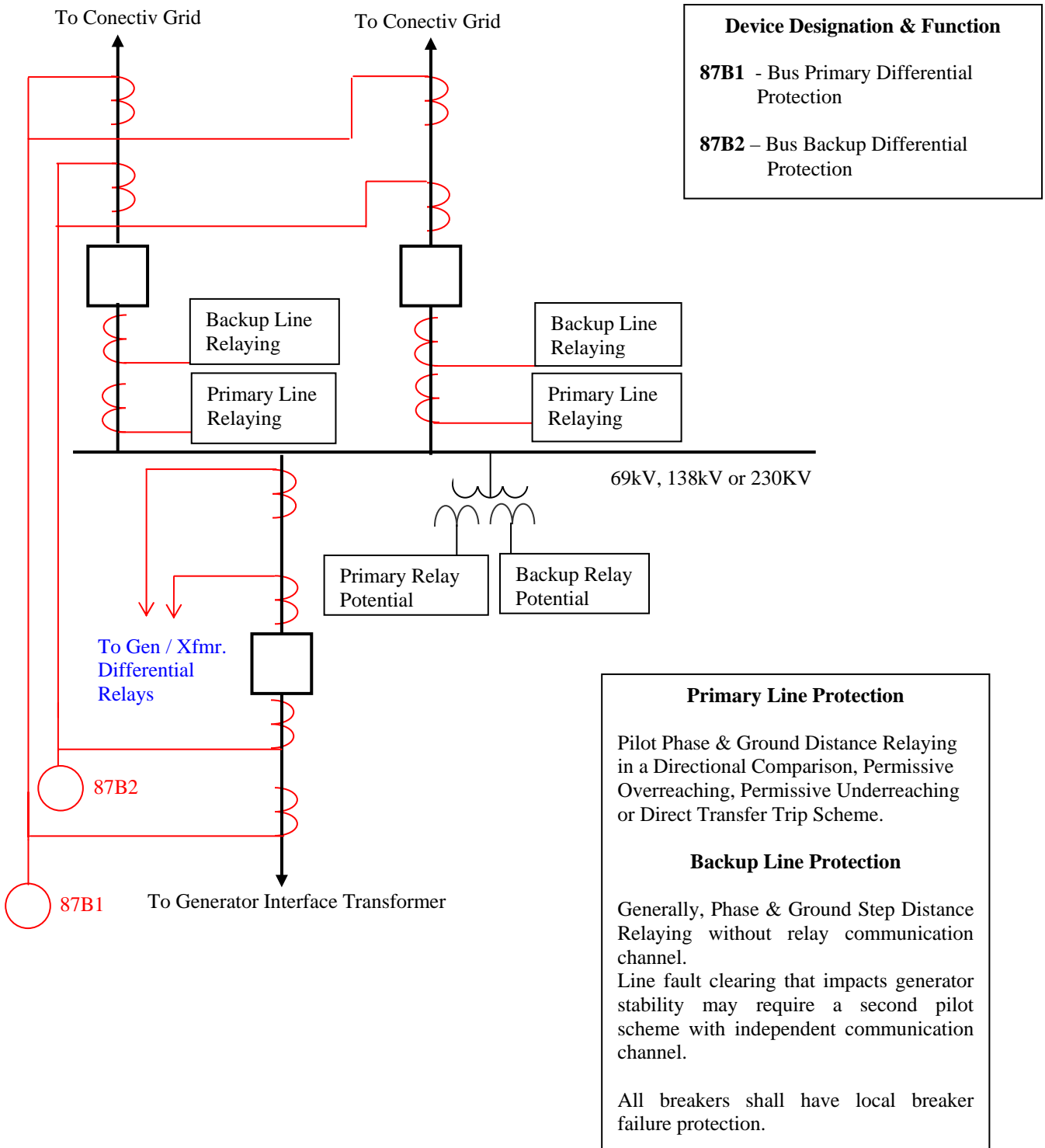
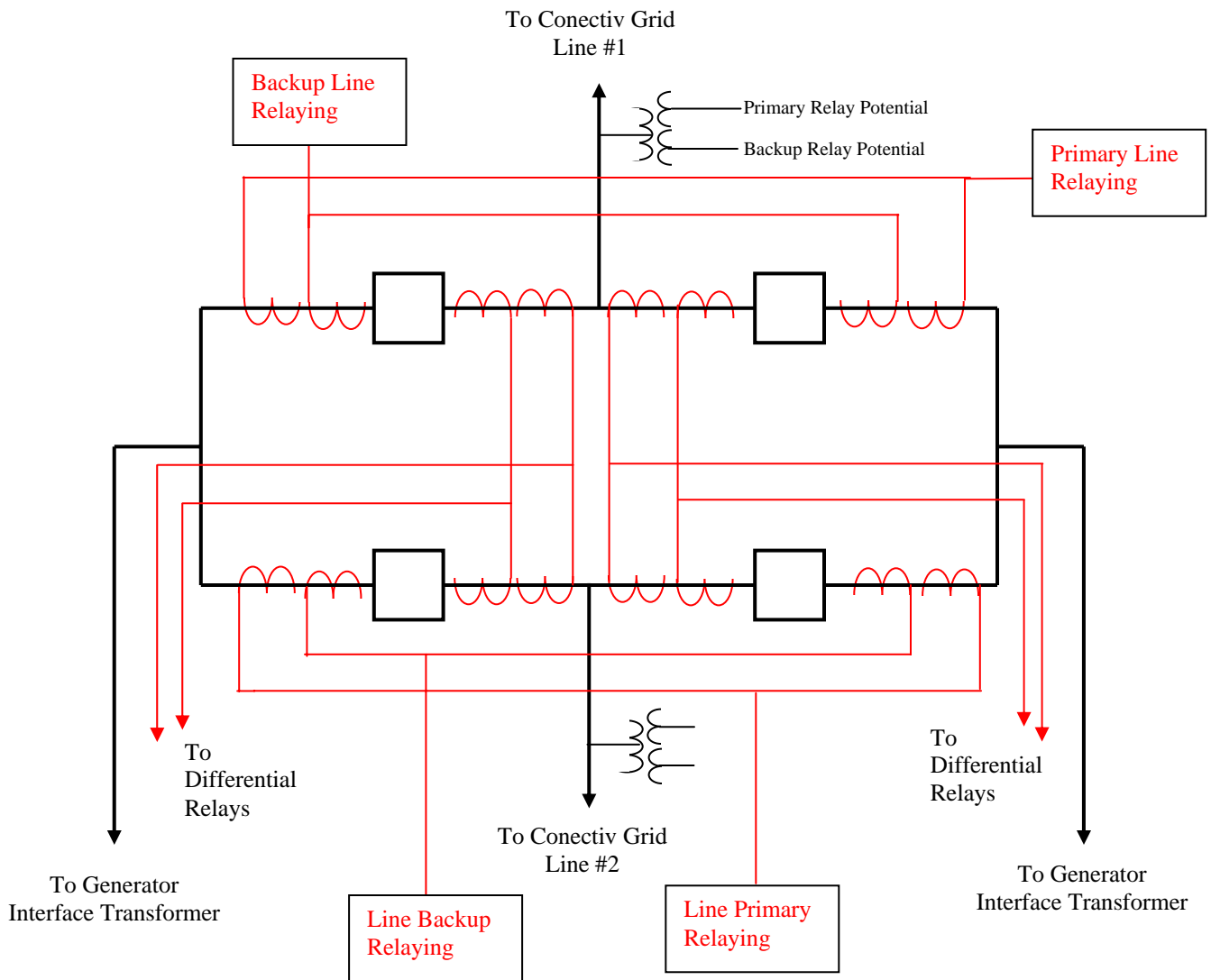

Figure 6, Typical Sample High Voltage Interface Substation with Ring Bus Configuration



Primary Line Protection
 Pilot Phase and Ground Distance Relaying in a Directional Comparison, Permissive Overreaching, Permissive Underreaching or Direct Transfer Trip Scheme.

Backup Line Relaying
 Generally, phase and ground Step Distance Relaying without relay communication channel. Line fault clearing that impacts generator stability may require a second pilot scheme with independent communication channel.
 All breakers shall have local breaker failure protection.

XII. Interconnection Application

- A. The proposed Generator Owner shall submit an Interconnection Application to the Company for approval to connect and operate a generating unit in parallel with the Company Grid. This application should be made as far in advance as possible of the tentative planned in service date. In general, the larger the proposed generating unit, the more lead time is needed to review all aspects of the interconnection and to finalize the Facility design. In addition, those Generator Owners who plan to sell into the PJM market must also submit the necessary applications to PJM and enter the PJM application queue. (The PJM application process is outside the scope of this document and the proposed Generator Owner will have to contact PJM directly on these issues.)
- B. Early application submission can also be cost advantageous to the proposed Generator Owner. The Conectiv Power Delivery System near the proposed generator site may require extensive and costly upgrades in order to accommodate the output of the generator. These upgrade costs may make the proposed site undesirable for the project. Early application should make this information known before the proposed Generator Owner has made extensive design and site purchase/work expenditures.
- C. Early application submission is also advantageous to the Company and assists the Company in meeting the Generator Owner's time schedule. The Company will have to assign resources, do engineering and order material necessary for any Grid upgrades. The earlier this process is started, the easier it is for the Company to meet the Generator Owner's proposed in service date.
- D. The Generator Owner shall complete an Interconnection Application Form and supply as much information as possible. It is realized that some information will probably not be available at the time of the initial application submission. However, the Generator Owner should supply as much information and details as possible and forward other necessary information as soon as it becomes available.
- E. A One-Line Diagram for the entire proposed Facility shall accompany the Interconnection Application. The diagram shall include details on the connection and rating of all equipment and show all protective schemes. In addition, transformer and generator impedance characteristics and dynamic modeling data must be submitted. (See Appendix B)
- F. Details on how the proposed Facility is to be operated and the anticipated range of power to be exported into the Company Grid should be included with the Interconnection Application.
- G. The Company reserves the right to request additional data, information details and drawings necessary to fully review the proposed Facility and to insure coordination of all equipment with the Company Grid.
- H. Following submission of the Interconnection Application, the Company, the Generator Owner and the Generator Owner's technical consultants will institute a series of meetings to review and discuss the proposed Facility. The comments and feedback from the Company at these meetings will enable the Generator Owner to finalize his design and operating requirements.
- I. In addition to reviewing the data, drawings and specifications provided by the Generator Owner, the Company may elect to physically inspect the Generator Owner's site during and after construction to insure adherence to the information supplied.
- J. All protection, control schemes, metering and RTU operations must be functionally tested and operating correctly before the Company can approve the interconnection.
- K. The Company reserves the right to witness testing of the Generator Owner's protection and control schemes and to request copies of any test data/results. In witnessing any testing, the Company

assumes no liability as the full responsibility of Facility operation and protection rests with the Generator Owner.

- L. The Generator Owner can interconnect with the Company Grid and commence parallel operation only after the Company has provided written approval to interconnect.

XIII. References

The references and standards listed below can provide technical requirements, support and insight into the safe, reliable interconnection of parallel generation with the Conectiv Power Delivery Grid. It is suggested that those individuals and firms contemplating operation of parallel generation with the Company review these references for applicability to their installation. This listing is not intended to be all-inclusive.

- IEEE C2, National Electric Safety Code® (NESC®)
- NFPA 70, National Electric Code® (NEC®)
- IEEE Std. 493-1997, *IEEE Recommended Practice for Design of Reliable Industrial and Commercial Power Systems* (IEEE Gold Book)
- IEEE Std. 519-1992, *IEEE Recommended Practice and Requirements for Harmonic Control in Electric Power Systems*
- IEEE Std. 242-1986, *IEEE Recommended Practice for Protection and Coordination of Industrial and Commercial Power Systems* (IEEE Buff Book)
- ANSI Std. C84.1-1995, *Electric Power Systems and Equipment – Voltage Ratings*
- IEEE Std. 1159-1995, *IEEE Recommended Practice for Monitoring Power Quality*
- IEEE Std. 929-2000, *IEEE Recommended Practice for Utility Interface of Photovoltaic (PV) Systems*
- ANSI/IEEE Std. C37.1-1994, *Standard Definitions, Specifications and Analysis of Systems Used for Supervisory Control, Data Acquisition and Automatic Control*
- IEEE Std. C37.2-1991, *IEEE Standard Electric Power System Device Function Numbers*
- IEEE Std. C37.90-1989, *Standard for Relays and Relay Systems Associated with Electric Power Apparatus*
- IEEE Std. C37.90.1-1989, *Standard Surge Withstand Capability (SWC) Tests for Protective Relays and Relay Systems*
- IEEE Std. C37.91-1985 (Reaff 1990), *Guide for Protective Relay Application to Power Transformers*
- IEEE Std. C37.93-1987, *IEEE Guide for Power System Protective Relay Applications of Audio Tones over Telephone Channels*
- IEEE Std. C37.95-1989, *IEEE Guide for Protective Relaying of Utility Consumer Interconnections*
- IEEE Std. C37.97-1979 (Reaff 1990), *Guide to Protective Relay Applications to Power System Buses*
- IEEE Std. C37.101-1985, (Reaff 1990) *Guide for Generator Ground Protection*

- IEEE C37.102-1987, (Reaff 1990) *Guide for AC Generator Protection*
- IEEE C37.103-1990, *Guide for Differential and Polarizing Relay Circuit Testing*
- IEEE C37.106-1987, *Guide for Abnormal Frequency Protection of Power Generating Plants*
- IEEE Std. C37.110-1996, *Guide for the Application of Current Transformers Used for Protective Relaying Purposes*
- IEEE Std. C37.113-1999, *Guide for Protective Relaying Applications to Transmission Lines*
- IEEE Std. C57.13.1-1981 (Reaff 1986) *Guide to Field Testing of Relaying Current Transformers*
- IEEE Std. C57.13.2-1986 *Standard Conformance Test Procedures for Instrument Transformers*
- IEEE Std. C57.13.3-1983 (Reaff 1990) *Guide for the Grounding of Instrument Transformer Secondary Circuits and Cases*
- IEEE Std. 100-1996, *IEEE Standard Dictionary of Electrical and Electronics Terms*
- IEEE Std. 141-1993, *Recommended Practice for Electric Power Distribution for Industrial Plants* (IEEE Red Book)
- IEEE Std. 1001-1988, *Guide for Interfacing Dispersed Storage and Generation Facilities with Electric Utility Systems*
- IEEE Std. 1021-1988, *IEEE Recommended Practices for Utility Interconnection of Small Wind Energy Conversion Systems*
- IEEE Std. P1547 Draft, *Standard for Distributed Resources Interconnected with Electric Power Systems*
- UL Subject 1741, May 1999, *Standard for Static Inverters and Charge Controllers for use in Photovoltaic Power Systems*
- *PJM Protective Relaying Philosophy and Design Standards*
- *PJM Relay Testing and Maintenance Practices*
- *PJM Transmission Substation and Line Design, Application and Maintenance Guidelines*
- *MAAC Protective Relaying Philosophy and Design Standards*
- *NERC Planning Standards*

APPENDIX A

CONNECTIV POWER DELIVERY GENERATOR PROTECTION GUIDELINES FOR UNITS 50 MW and ABOVE

The following discussion and guidelines are intended to be a basis for considering what protection to apply to both new units and those being upgraded.

Some specific protection applications may also be required as the result of consultation with the generator manufacturer.

Generator protection, like that on transmission lines, buses and transformers should be designed for reliability. This means an artful balance of dependability and security. Dependability is a measure of the protective relaying systems certainty to trip when required and security a measure of the ability not to trip falsely. The balancing of these two requirements involves consideration of independent ac current and voltage sources to the front line and backup relay schemes. Also independently protected dc control circuits should be used with the front-line and backup relay schemes.

In those cases which follow, if the need for both front-line and backup relays is not defined, one protective scheme will be adequate.

1.0 Generator Stator Fault Protection

1.1 General Consideration

Generator stator faults are very serious and cause costly damage. Because of the obvious importance of generators, the fault must be detected and cleared in the least amount of time possible. Because of the stored rotating energy of the generator, damage may occur after all the required breakers have been tripped.

1.2 Phase Fault Protection

Use a front-line current differential relay scheme and an independent backup differential scheme with independent current sources and independently protected dc control circuits. Each of these schemes should trip the generator breakers, excitation system and turbine valves.

1.3 Ground Fault Protection

High impedance grounding of generators is an accepted industry practice. This is done to limit the magnitude of ground fault current. Ground fault protection should include two independent relay schemes, employing independent current or voltage sources and independently protected dc control circuits. Each scheme should trip the generator breakers, excitation system and turbine valves.

2.0 Generator Rotor Field Protection

The generator rotor field winding is ungrounded. One ground on this field will not effect the generator's operation. The first ground, however, greatly increases the likelihood of a second ground occurring, causing imbalances and overheating. Generators should be equipped with rotor ground fault protection which will alarm only. Upon receipt of this alarm, the generator's load should be reduced to zero and the generator shut down as quickly as possible.

3.0 Generator Abnormal Operating Conditions

3.1 Loss of Field

Loss of field (loss of excitation) will result in loss of synchronism. Detection of this loss of field is usually done with impedance type relays. A front-line and independent backup scheme is required with each providing a simultaneous trip of the generator breakers, excitation system and turbine valves.

3.2 Unbalanced Currents

Unbalanced, or negative sequence currents, are the result of unbalanced loading. This could be the result of one phase open or unbalanced system faults which are not cleared properly. The unbalanced currents themselves cause generator rotor overheating. Protection requires a negative sequence time overcurrent relay with sensitivity sufficient to detect unbalanced conditions exceeding the continuous rating of the generator. The protection should initiate an alarm at one level and a unit trip at a higher level.

3.3 Loss of Synchronism

Loss of synchronism, out of step and pole slipping are all synonymous and can result from transients, dynamic instability or loss of excitation. This condition can be damaging to the unit. Detailed stability studies can determine if out of step protection is required. As a rule, if an impedance swing enters the generator or step up transformer impedance, out of step protection is necessary. When out of step protection is required, the generator should be tripped within the first slip cycle.

3.4 Overexcitation

Excessive flux (overexcitation) in the generator core can cause rapid overheating. Volts/Hertz is a measure of this condition. Two independent schemes should be used, each providing protection for the volts/hertz rating of the generator. An initial alarm followed by a simultaneous trip of the generator breakers, excitation system and turbine valves is recommended.

3.5 Reverse Power (Anti-Motoring)

Generator motoring is caused by the lack of energy supplied to the prime mover resulting in the electrical system driving the machine as a motor. Synchronous motoring will not damage the generator, but will cause damage to the prime mover. Anti-motoring protection should initiate an alarm which will be followed after a defined time by a unit trip (generator breakers, excitation system and turbine valves).

3.6 Abnormal Frequencies

Generators can withstand off frequency operation for long periods of time, provided the load and voltage are reduced a sufficient amount. The turbine, however, can be subject to resonance caused by the off frequency operation. The usual frequency excursion is to a lower than 60 hertz operation. Automatic system wide load shedding is the primary protection against this condition. For protection of the turbine, underfrequency relays set at 57.5 hertz and a five second tripping delay are required. For security, two underfrequency relays connected in series for tripping and using independent voltage sources should be used. A sequential trip of the turbine valves, excitation system and generator breakers is recommended.

4.0 Generator Breaker Failure Protection

Breaker failure protection must be provided for all relay initiated generator trips. It should be noted that all generator abnormalities that require the generator to be tripped will not result in an overcurrent condition (off frequency, unbalanced currents, etc.). For these conditions, current actuated fault detectors lack sensitivity to monitor breaker open/close status and breaker auxiliary switches should be used instead.

5.0 Excitation System Tripping

All protective relay trips of the generator excitation system should trip redundant systems. This could be tripping the main field breaker and exciter field or simultaneous tripping of the main field breaker and activation of the de-excitation system.

6.0 Generator Open Breaker Flashover Protection

Open breaker flashover is more likely on generator breakers. Protection for this must be provided for all gas and/or air circuit breakers.

7.0 Protection During Start Up or Shutdown

During start up or shutdown the generator may be operated at less than rated frequency. During this time, adequate protection must be provided. Some relays, however, are frequency sensitive. Each of the relays' operating characteristics versus frequency must be checked to ensure proper operation at frequencies below 60 Hz. If relay operation is questionable, additional protective relaying will have to be added.

8.0 Protection for Accidentally Energizing a Generator on Turning Gear

Accidental energization of a generator while off line or on turning gear has become of increasing concern in recent years. Severe damage to the generator can occur in a very short time. To provide adequate protection for accidental energization, a scheme designed specifically for this is required. This scheme must trip all associated generator breakers.

9.0 Synchronizing Equipment

Each generator should be equipped with a scheme that supervises manual synchronizing. For system emergency restoration, the generator breakers should be capable of closing on a dead system.

10.0 Generator Lead Protection

The generator lead, in other words, the phase conductors from the generator terminals to the unit power transformer and the unit auxiliary transformer should be protected by a primary current differential relay scheme. A backup differential relay scheme is required if:

- 1) The conductors are not segregated into bus ducts for their entire exposure, or
- 2) The generator is not grounded through a high impedance to limit ground faults to levels undetectable by current differential relays.

A simultaneous trip of the generator breakers, excitation system and turbine valves is recommended.

APPENDIX B

Information To Be Supplied By Generator Owner

The following information must be supplied by the Generator Owner to allow the Company to conduct necessary studies and reviews to assess the impact of the proposed Facility on the Conectiv Power Delivery System, and to quantify what, if any, upgrades are required to accommodate the proposed generation addition at the specified Point of Common Coupling.

It is recognized that some information will not be available at the time of initial application submission. However, the Generator Owner should supply as much information and detail as possible and forward other necessary information as soon as it becomes available.

At the very least, data requested in Sections A through G, H1 and L should accompany the initial application submission.

- A. Name of Generator Owner
- B. Name, address, telephone number, and E-mail address of individual able to answer technical questions relating to the design and operation of the proposed Facility
- C. Exact location of proposed Point of Common Coupling
- D. Type (Synchronous, Induction, Inverter, etc), and rating of proposed generator(s)
- E. Estimated maximum and minimum Facility load at Point of Common Coupling with generation in service
- F. Estimated maximum and minimum Facility load at Point of Common Coupling without generation in service
- G. Estimated maximum power anticipated to be exported into the Conectiv Power Delivery System
- H. The Generator Owner shall provide copies of the following drawings to the Company for their review:
 - 1. A one line diagram of Facility.
 - 2. All potential elementaries associated with the protection and control schemes for the generator and interconnection equipment.
 - 3. All current elementaries associated with the protection and control schemes for the generator and interconnection equipment.
 - 4. A control elementary of the generator breaker and the interconnection breaker.
 - 5. A three line diagram of generation system.

- I. The One Line Diagram And Three Line Diagram shall include the following information:
1. Equipment names and/or numerical designations for all circuit breakers, contactors, air switches, transformers, generators, etc. associated with the generation as required by the Company to facilitate switching.
 2. Power Transformers – name or designation, nominal kVA, nominal primary, secondary, tertiary voltages, vector diagram showing winding connections, tap setting and transformer impedance. A copy of the transformer nameplate and test report can be substituted.
 3. Station Service Transformers – Designate phase(s) connected to and estimated kVA load.
 4. Instrument Transformers – Voltage and current, phase connections.
 5. Surge Arresters/Gas Tubes/Metal Oxide Varistors/Avalanche Diode/Spill Gaps/Surge Capacitors, etc. – Type and Ratings.
 6. Capacitor Banks – kVAR rating.
 7. Disconnect Switches – Indicate status normally open with a (N.O.) and whether manual or motor operated. Include switch voltage, continuous and interrupting ratings.
 8. Circuit Breakers and/or Contactors – Interrupting rating, continuous rating, operating times.
 9. Generators(s) – Include nameplate , test report, type, connection, kVA, voltage, current, rpm, PF, impedances, time constants, etc.
 10. Point of Interconnection to Conectiv Power Delivery System and phase identification.
 11. Fuses – Manufacturer, type, size, speed, and location.
- J. Elementary Diagrams shall include the following information:
1. Terminal designation of all devices – relay coils and contacts, switches, transducers, etc.
 2. Relay functional designation – per latest ANSI Standard. The same functional designation shall be used on all drawings showing the relay.
 3. Complete relay type (such as CV-2, SEL321-1, REL-301, IJS51A, etc.)
 4. Switch contact shall be referenced to the switch development if development is shown on a separate drawing.
 5. Switch developments and escutcheons shall be shown on the drawing where the majority of contacts are used. Where contacts of a switch are used on a separate drawing, that drawing should be referenced adjacent to the contacts in the switch development. Any contacts not used should be referenced as spare.
 6. All switch contacts are to be shown open with each labeled to indicate the positions in which the contact will be closed.

7. Explanatory notes defining switch coordination and adjustment where mis-adjustment could result in equipment failure or safety hazard.
 8. Auxiliary relay contacts shall be referenced to the coil location drawing if coil is shown on a separate drawing. All contacts of auxiliary relays should be shown and the appropriate drawing referenced adjacent to the respective contacts.
 9. Device auxiliary switches (circuit breakers, contactor) should be referenced to the drawing where they are used.
 10. Any interlocks electromechanical, key, etc., associated with the generation or interconnection substation.
 11. Ranges of all timers and setting if dictated by control logic.
 12. All target ratings; on dual ratings note the appropriate target tap setting.
 13. Complete internal for electromechanical protective relays. Microprocessor relays may be shown as a "black box", but manufacturer's instruction book number shall be referenced and terminal connections shown.
 14. Isolation points (states links, PK-2 and FT-1 blocks), etc., including terminal identification.
 15. All circuit elements and components, with device designation, rating and setting where applicable. Coil voltage is shown only if different from nominal control voltage.
 16. Size, type, rating and designation of all fuses.
 17. Phase sequence designation as ABC or CBA.
 18. Potential transformers – nameplate ratio, polarity marks, rating, primary and secondary connections (see Guidelines for minimum ratings.)
 19. Current transformers (including aux. CT's) – polarity marks, rating, tap ratio and connection.
- K. Documentation of all protective device settings shall be provided. The setting documentation shall also include relay type, model/catalog number and setting range. If automatic transfer schemes, or unique or special protective schemes are used, a description of their operation should be included. The Company must review and approve the settings of all protective devices and automatic control equipment which: (1) serve to protect the Conectiv Power Delivery System from hazardous currents and voltages originating from the Facility or (2) must coordinate with protective devices or control equipment located on the Conectiv Power Delivery System.
- L. The following modeling data must be supplied to the Company and/or PJM to allow necessary interconnection studies to be performed. It is recognized that some of this data may initially be preliminary in nature. Interconnection studies will be based on data submitted. Any changes, or modifications, to this data after the interconnection study has been completed may render the analysis invalid and require re-opening of the interconnection study. It is the Generator Owners responsibility to make the Company and / or PJM aware of any changes to this data, and to provide final certified test reports and modeling data as soon as it is available.

Unit Capability Data

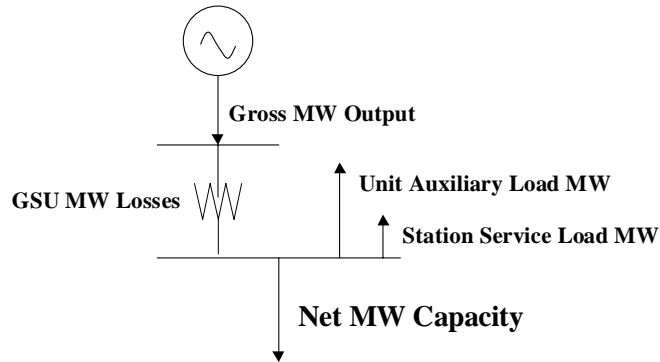

$$\text{Net MW Capacity} = (\text{Gross MW Output} - \text{GSU MW Losses} - \text{Unit Auxiliary Load MW} - \text{Station Service Load MW})$$

PJM Queue Letter/Position/Unit ID: _____

Primary Fuel Type: _____

Maximum Summer (92° F ambient air temp.) Net MW Output: _____

Maximum Summer (92° F ambient air temp.) Gross MW Output: _____

Minimum Summer (92° F ambient air temp.) Gross MW Output: _____

Maximum Winter (30° F ambient air temp.) Gross MW Output: _____

Minimum Winter (30° F ambient air temp.) Gross MW Output: _____

Gross Reactive Power Capability at Maximum Gross MW Output (Leading and Lagging): _____

***** Please submit Reactive Capability Curve when available**

Individual Unit Auxiliary Load at Maximum Summer MW Output (MW/MVAR): _____

Individual Unit Auxiliary Load at Minimum Summer MW Output (MW/MVAR): _____

Individual Unit Auxiliary Load at Maximum Winter MW Output (MW/MVAR): _____

Individual Unit Auxiliary Load at Minimum Winter MW Output (MW/MVAR): _____

Station Service Load (MW/MVAR): _____

Please provide any comments on the expected capability of the unit:

Unit Generator Dynamics Data

PJM Queue Letter/Position/Unit ID: _____

MVA Base (upon which all reactances, resistance and inertia are calculated): _____

Nominal Power Factor: _____

Terminal Voltage (kV): _____

Unsaturated Reactances (on MVA Base)

Direct Axis Synchronous Reactance, $X_{d(i)}$: _____

Direct Axis Transient Reactance, $X'_{d(i)}$: _____

Direct Axis Sub-transient Reactance, $X''_{d(i)}$: _____

Quadrature Axis Synchronous Reactance, $X_{q(i)}$: _____

Quadrature Axis Transient Reactance, $X'_{q(i)}$: _____

Quadrature Axis Sub-transient Reactance, $X''_{q(i)}$: _____

Stator Leakage Reactance, X_l : _____

Negative Sequence Reactance, $X_{2(i)}$: _____

Zero Sequence Reactance, X_0 : _____

Saturated Sub-transient Reactance, $X''_{d(v)}$ (on MVA Base): _____

Armature Resistance, R_a (on MVA Base): _____ at _____ ° C

Time Constants (seconds)

Direct Axis Transient Open Circuit, T'_{do} : _____

Direct Axis Sub-transient Open Circuit, T''_{do} : _____

Quadrature Axis Transient Open Circuit, T'_{qo} : _____

Quadrature Axis Sub-transient Open Circuit, T''_{qo} : _____

Inertia, H (kW-sec/kVA, on KVA Base): _____

Speed Damping, D : _____

Saturation Values at Per-Unit Voltage [S(1.0), S(1.2)]: _____

Please submit generator certified test report information when available

IEEE dynamic model parameters:

Governor Model: _____

Exciter Model: _____

Power System Stabilizer Model: _____

Unit Transformer Data

PJM Queue Letter/Position/Unit ID: _____

Generator Step-up Transformer MVA Base: _____

Generator Step-up Transformer Impedance (R+jX, on transformer MVA Base): _____

Generator Step-up Transformer Rating (MVA): _____

Generator Step-up Transformer Low-side Voltage (kV): _____

Generator Step-up Transformer High-side Voltage (kV): _____

Generator Step-up Transformer Off-nominal Turns Ratio: _____

Generator Step-up Transformer Number of Taps and Step Size: _____

Please submit transformer certified test report information when available

In addition, please indicate whether the transformer is shared with other units.